

MACT302 series

AIR UNITS (F.R.L.UNIT)



mindman

Specification

Model	MACT302		
Components	MAF302, MAR302, MAL302		
Bore No.	8A	10A	15A
Port size	1/4	3/8	1/2
Medium	Air		
Operating pressure range (※)	0.05~1 MPa		
Proof pressure	1.5 MPa		
Effective orifice	32mm ²	34mm ²	
Regulated pressure range	0.05~0.85 MPa		
Ambient temperature	-5~+60°C (No freezing)		
Filter element	Standard: 5 μm ORcion: 40 μm		
Lubricating oil capacity	65c.c		
Min. Flow for oil drip	50 ℓ/min	60 ℓ/min	
Recommended lubricating oil	Turbine oil ISO-VG32		
Attachment	Pressure gauge(PG-20), T-type bracket		
Weight	1115 g		

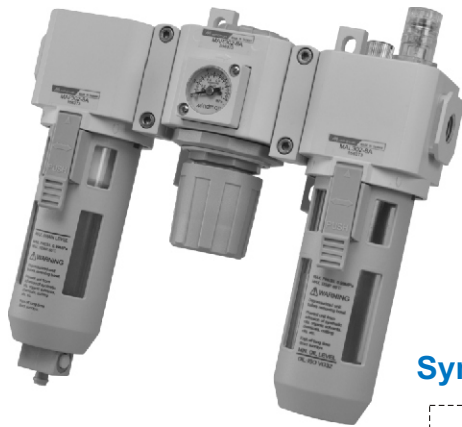

Option: MP41

Symbol

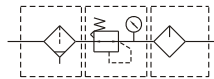

Order example

MACT302 - 8A - □ - □ - T8 - G

MODEL

BORE SIZE

8A : 1/4
10A : 3/8
15A : 1/2

C: External pressure gauge (PG-40)

D: Auto drain valve (FMRF300)
※ Refer to page E-13 for the option of digital pressure switch MP41.

FILTER ELEMENT

Blank: 5 μm
40u: 40 μm

PORT THREAD

Blank: Rc thread
G: G thread
NPT: NPT thread

Module mounting bracket

T8: 1/4
T10: 3/8
T15: 1/2

※1. Standard unit contains semi-auto-drain function when operating pressure below 0.05 MPa.

※2. Choose auto-drain FMRF300, the pressure range is 0.15 ~ 1 MPa.

Flow feature

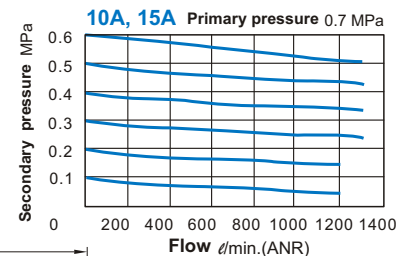
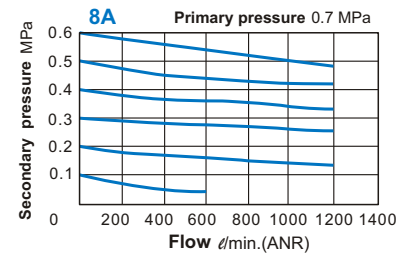

MACT302-D Auto drain valve

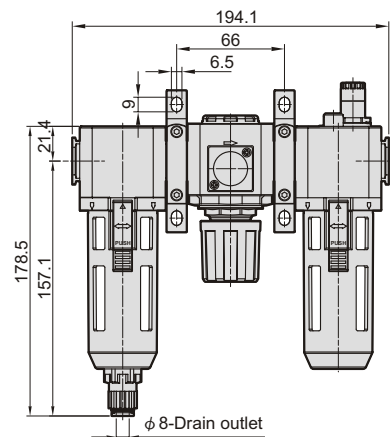

MACT302-T* Module mounting bracket

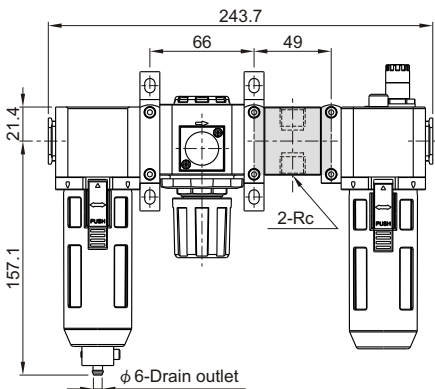

	Rc
T8	Rc1/4
T10	Rc3/8
T15	Rc1/2

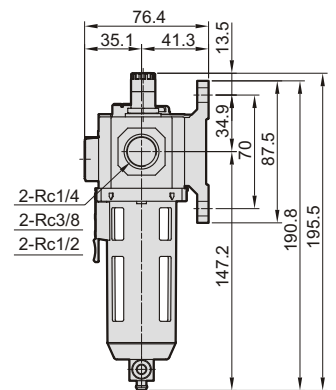
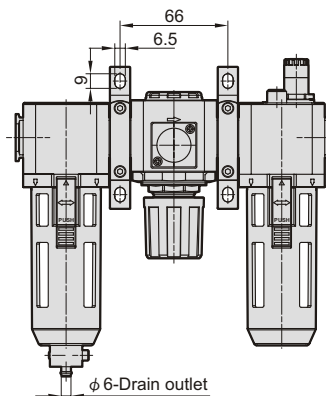
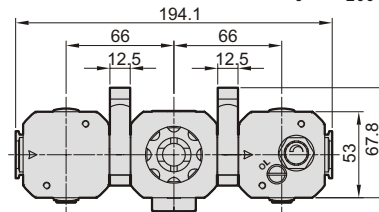

mindman