

MAFRF401 series

AIR UNITS (F.R.UNIT)



Mindman



Specification

Model	MAFRF401		
Bore No.	8A	10A	15A
Port size	1/4	3/8	1/2
Medium	Air		
Operating pressure range (※)	0.05~1.5 MPa		
Proof pressure	2 MPa		
Regulated pressure range	Standard type:0.1~0.85 MPa		
	High pressure type: 0.1~1.5 Mpa		
Ambient temperature	-5~+60℃ (No freezing)		
Filter element	5 μm+0.3 μm		
Weight	1453 g		
Attachment	Pressure gauge (PG-20)		

※1. Standard unit contains semi-auto-drain function when operating pressure below 0.05 MPa.

※2. Choose auto-drain FMRF300, the pressure range is 0.15 ~ 1 MPa.

Symbol

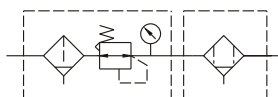

Order example

MAFRF401AD - 8A - [] - B - []

MODEL

FILTER ELEMENT

AD: 5 μm+0.3 μm

BORE SIZE

8A: 1/4
10A: 3/8
15A: 1/2

Blank: standard type

C: external pressure gauge (PG-40)

D: auto drain valve (FMRF300)

H: high pressure type (Required with external pressure gauge PG-40)

B: C type bracket

PORT THREAD

Blank: Rc thread

G: G thread

NPT: NPT thread

※1. (H) High pressure type can not choose with auto drain valve (FMRF300) when operating pressure over than 1 MPa.

※2. Refer to page E-14 for the option of digital pressure switch MP41.

Option accessories

C type bracket

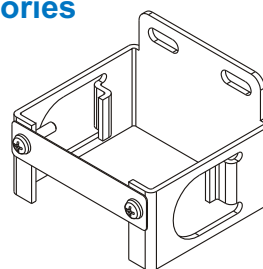

MAFRF401

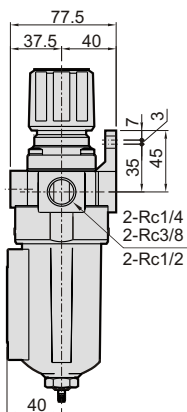
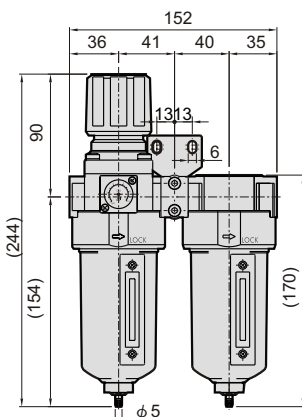

MAFRF401-B

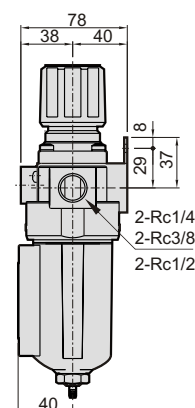
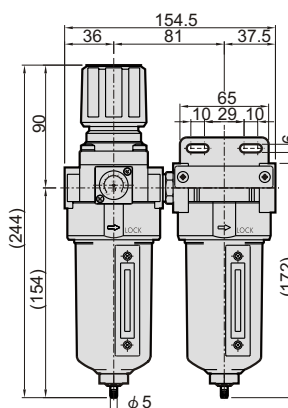

Mindman