

MAL400 series

AIR UNITS (L.UNIT)



mindman



Symbol

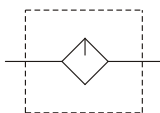

Specification

Model	MAL400		
Bore No.	8A	10A	15A
Port size	1/4	3/8	1/2
Medium	Air		
Max. operating pressure	1 MPa		
Proof pressure	1.5 MPa		
Ambient temperature	-5~+60°C (No freezing)		
Lubricating oil capacity	200c.c		
Max. flow rate (※) ℓ/min	400	1300	2500
Min. flow for oil drip	50 ℓ/min	200 ℓ/min	400 ℓ/min
Recommended lubricating oil	Turbine oil ISO-VG32		
Option	Bracket		
Weight	600 g		

Order example

MAL400 – 10A – B – □

MODEL

BORE SIZE

8A: 1/4
10A: 3/8
15A: 1/2

B: bracket

PORT THREAD

Blank: Rc thread
G: G thread
NPT: NPT thread

※ Flow is at pressure P=0.7 MPa with pressure drop ΔP=0.03 MPa (ANR)

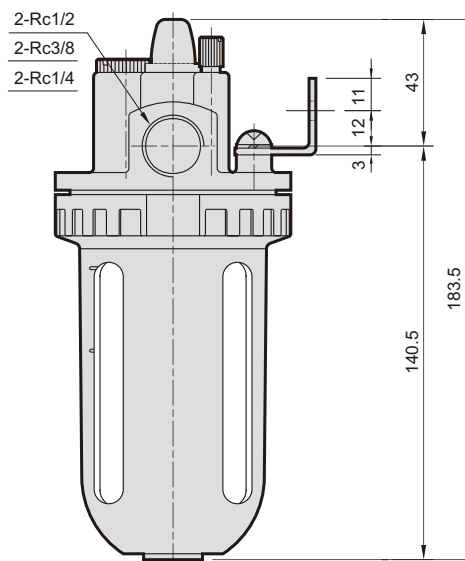
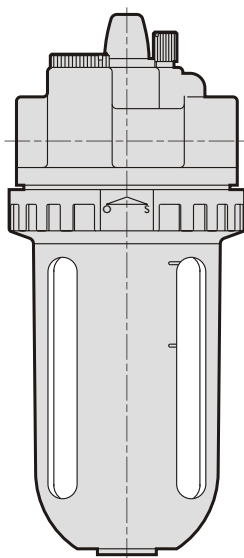
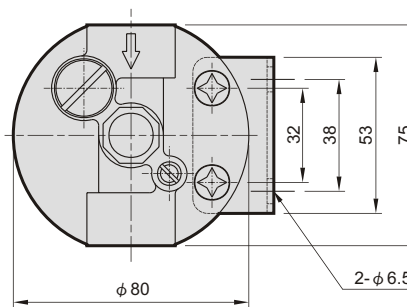

mindman