



### Features

#### ■ Non lubrication

Special housing and bushing enables self lubrication of piston rod.

#### ■ High quality long service life

Hard anodised aluminium cylinder tubes offer a high resistance to corrosion and low internal friction.

#### ■ Non standard type

Custom cylinders are available as are non standard strokes, rod extensions and special rod threads.

#### ■ Cylinder mountings

Available with comprehensive internationally recognised range of fixed and flexible mountings.

### Specification

Table for standard stroke

Tube I.D.	Stroke(mm)
φ 40	50,75,100,125,150,175,200,250,300,350,400,450,500
φ 50,63	↑ 600
φ 80,100	↑ 600,700
φ 125,150	↑ 600,700,800,900,1000
φ 200	↑ 600,700,800,900,1000,1500

- Stroke out of specification is also available.
- Please consult us if stroke out of specification.

Model	MCQA				
Tube I.D. (mm)	40,50,63	80,100	125	150	200
Medium	Air				
Operating pressure range	0.05~1 MPa				
Proof pressure	1.5 MPa				
Ambient temperature	-5~+60°C (No freezing)				
Available speed range	50~500 mm/sec				
Sensor switch (※)	RCA				
Sensor switch holder	HV2	HV4	PM14	PM16	HA5

※ RCA specification, please refer to page V-05.

### Order example

MCQA - 11 - 40 - 100 M - G

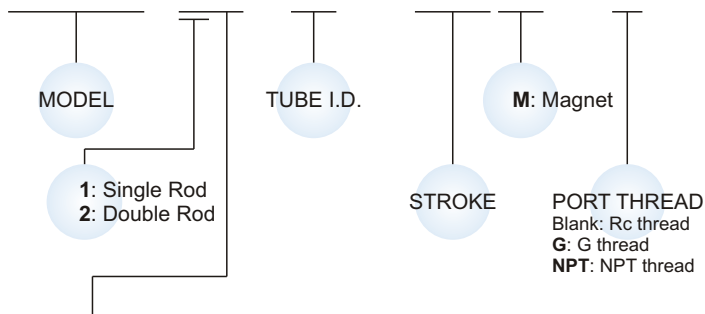

STYLE:

Code	Symbol	Description
1 1		Double acting / Male thread
2 1		Double rod / Male thread
2 7		Double rod / Adjustable male thread (Please mark "adjustable distance(mm)" at order list)

※ Order example for special specification, refer to page J-03.

### Mounting accessories

LB - MCQA - 40

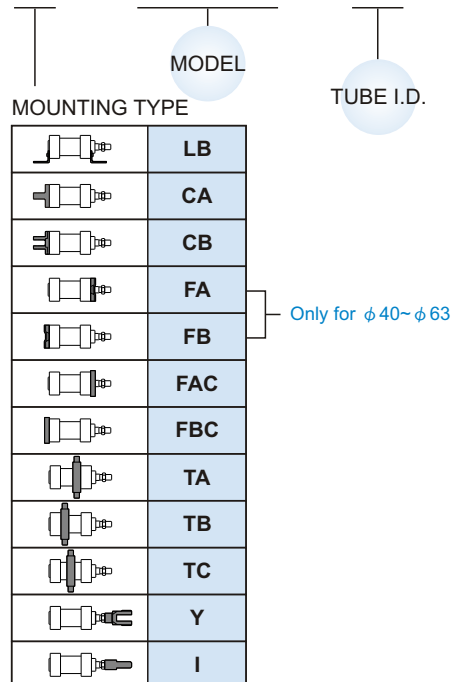

# MCQA-11 Inside structure & Parts list

## STANDARD CYLINDERS



Mindman

### Single rod 11 type

$\phi$  100

$\phi$  40~ $\phi$  100

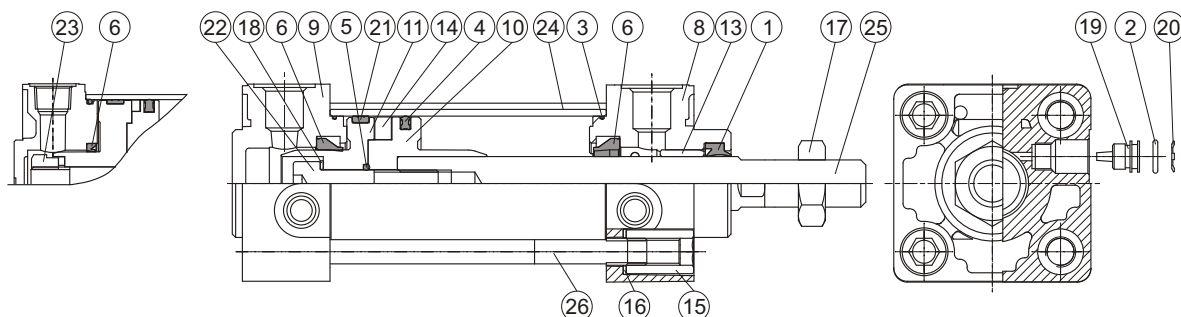

$\phi$  125~ $\phi$  200

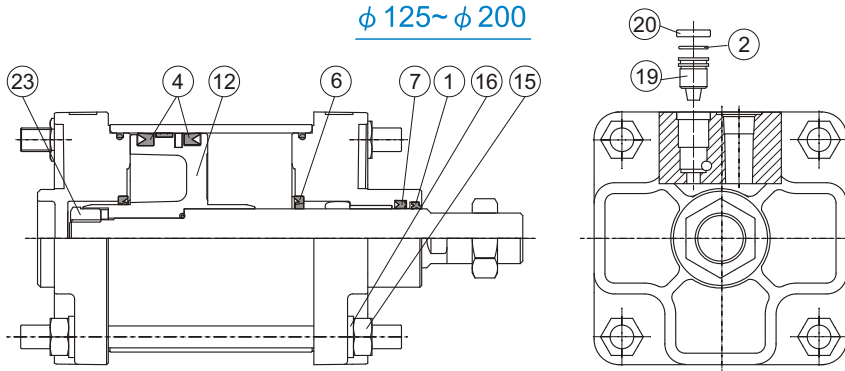

No.	Part name	Material	Q'y	Component parts (inclusion)		Repair kits (inclusion)	Note
				$\phi$ 40~ $\phi$ 100	$\phi$ 125~ $\phi$ 200		
01	Rod packing	NBR	1	●	●	●	
02	O-ring	NBR	2	●	●	●	
03	O-ring	NBR	2	●	●	●	
04	Piston packing	NBR	1 or 2	●	●	●	$\phi$ 125~ $\phi$ 200 (Q'y =2)
05	O-ring	NBR	1	●	●	●	
06	Cushion packing	NBR	2	●	●	●	Repair kits $\phi$ 40~ $\phi$ 80 (inclusion)
07	Rod packing	NBR	1		●	●	
08	Rod cover	Aluminum alloy	1	●	●		
09	Head cover	Aluminum alloy	1	●	●		
10	Piston-R	Aluminum alloy	1	●			
11	Piston-H	Aluminum alloy	1	●			
12	Piston	Aluminum alloy	1		●		
13	Bush	Bearing alloy	1	●	●		
14	Magnet ring	Magnet material	1	◎	◎		◎ Option
15	Tie rod nut	Carbon steel	8	●	●		
16	Tie rod washer	Carbon steel	8	●	●		
17	Nut	Carbon steel	1	●	●		
18	Washer	Carbon steel	1	●	●		
19	Needle valve	Copper alloy	2	●	●		
20	Needle valve washer	※1	2	●	●		
21	Wear ring	Teflon	1	●	●		
22	Bolt	Carbon steel	1	●			for $\phi$ 40~ $\phi$ 80
23	Piston nut	Carbon steel	1		●		for $\phi$ 100~ $\phi$ 200
24	Cylinder tube	Aluminum alloy	1				
25	Piston rod	Carbon steel	1				
26	Tie rod	Carbon steel	4				

※1: Spring steel ( $\phi$  40~ $\phi$  100) / Carbon steel ( $\phi$  125~ $\phi$  200).



Mindman

# MCQA-2\* Inside structure & Parts list

## STANDARD CYLINDERS



### Double rod 21 / 27 type

$\phi 40 \sim \phi 100$

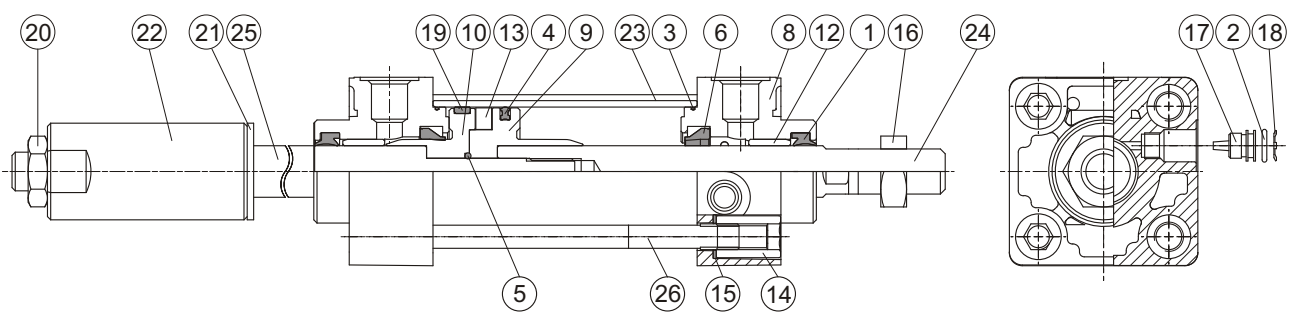

$\phi 125 \sim \phi 200$

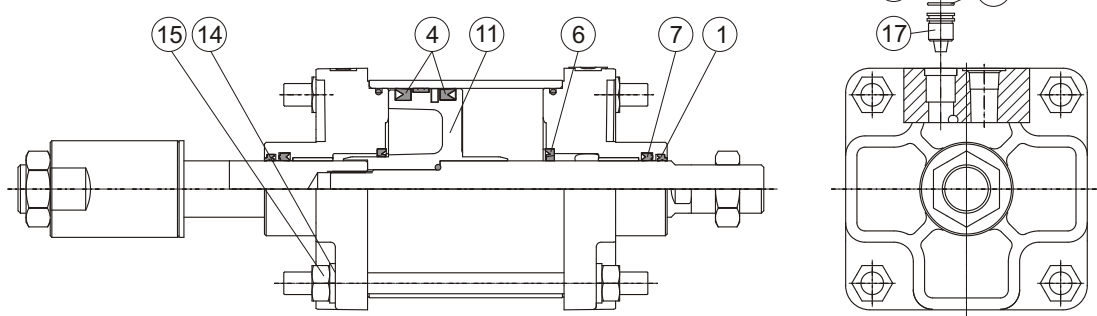

No.	21 type		27 type		Part name	Material	Q'y	Component parts (inclusion)		Repair kits (inclusion)		Note
	A	B	A	B				$\phi 40 \sim \phi 100$	$\phi 125 \sim \phi 200$	$\phi 40 \sim \phi 100$	$\phi 125 \sim \phi 200$	
01	●	●	●	●	Rod packing	NBR	2	●	●	●	●	
02	●	●	●	●	O-ring	NBR	2	●	●	●	●	
03	●	●	●	●	O-ring	NBR	2	●	●	●	●	
04	●	●	●	●	Piston packing	NBR	1 or 2	●	●	●	●	$\phi 125 \sim \phi 200$ (Q'y=2)
05	●	●	●	●	O-ring	NBR	1	●	●	●	●	
06	●	●	●	●	Cushion packing	NBR	2	●	●	●		Repair kits $\phi 40 \sim \phi 80$ (inclusion)
07		●		●	Rod packing	NBR	2		●		●	
08	●	●	●	●	Rod cover	Aluminum alloy	2	●	●			
09	●		●		Piston-R	Aluminum alloy	1	●				
10	●		●		Piston-H	Aluminum alloy	1	●				
11		●		●	Piston	Aluminum alloy	1		●			
12	●	●	●	●	Bush	Bearing alloy	2	●	●			
13	◎	◎	◎	◎	Magnet ring	Magnet material	1					◎ Option
14	●	●	●	●	Tie rod nut	Carbon steel	8	●	●			
15	●	●	●	●	Tie rod washer	Carbon steel	8	●	●			
16	●	●	●	●	Screw	Carbon steel	1	●	●			
17	●	●	●	●	Needle valve	Copper alloy	2	●	●			
18	●	●	●	●	Needle valve washer	※1	2	●	●			
19	●	●	●	●	Wear ring	Teflon	1	●	●			
20	●	●	●	●	Screw	Carbon steel	1	●	●			
21			●	●	Gasket	PU	1					
22			●	●	Adjustable nut	Carbon steel	1					
23	●	●	●	●	Cylinder tube	Aluminum alloy	1					
24	●	●	●	●	Piston rod #1	Carbon steel	1					
25	●	●	●	●	Piston rod #2	Carbon steel	1					
26	●	●	●	●	Tie rod	Carbon steel	4					

A:  $\phi 40 \sim \phi 100$ , B:  $\phi 125 \sim \phi 200$  ※1: Spring steel ( $\phi 40 \sim \phi 100$ ) / Carbon steel ( $\phi 125 \sim \phi 200$ ).



■ Order example of component parts

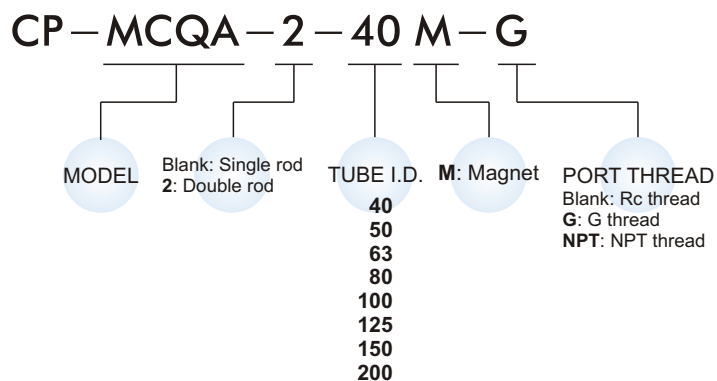

■ Order example of repair kits

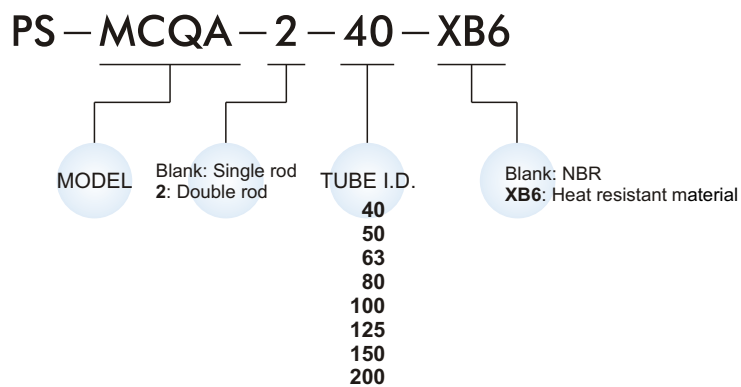

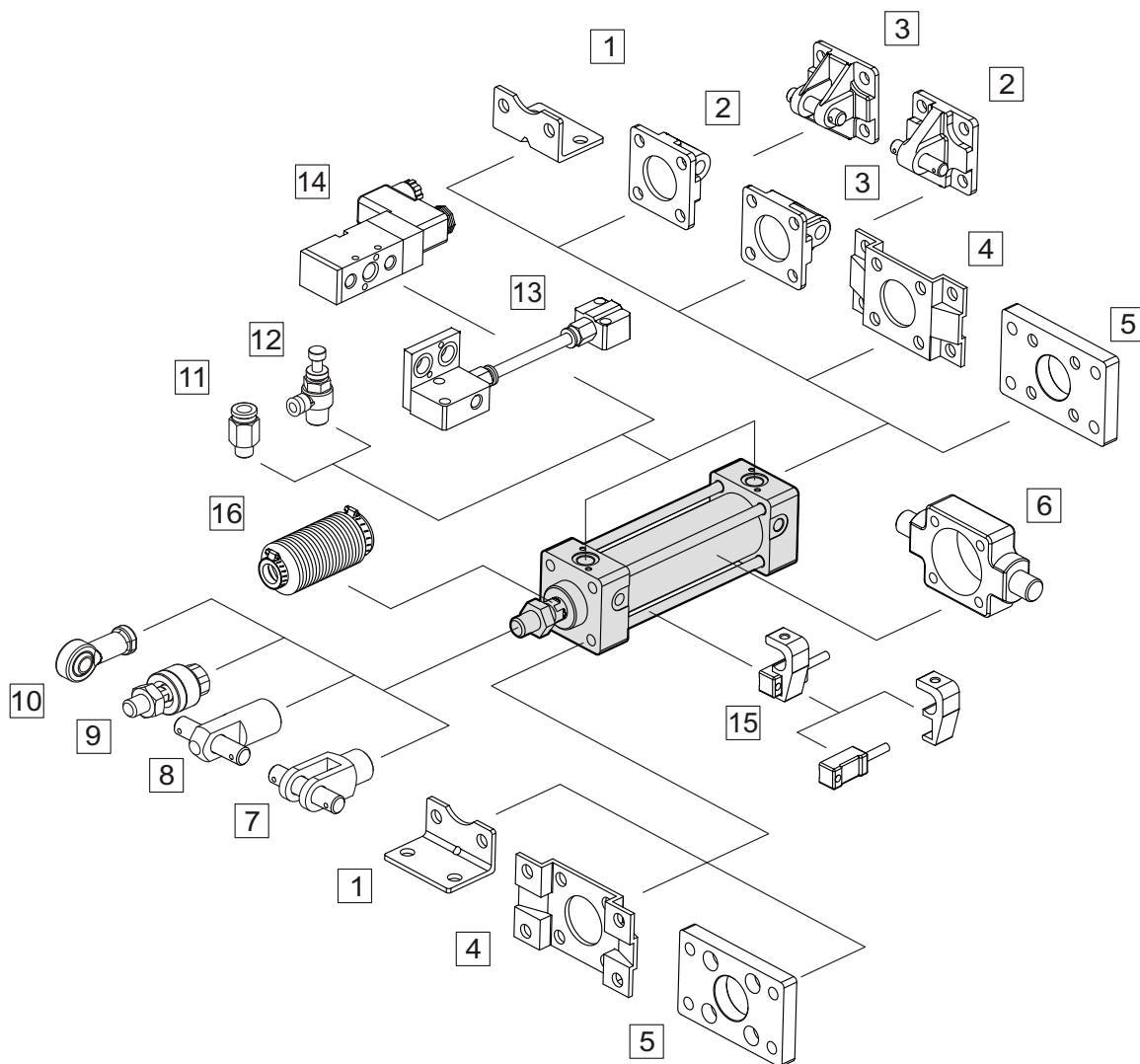

No.	Accessories	Page
1	Mounting accessories LB	J-19
2	Mounting accessories CA+PIN	J-22, 31
3	Mounting accessories CB+PIN	J-22, 31
4	Mounting accessories FA/FB	J-20, 21
5	Mounting accessories FAC/FBC	J-20, 21
6	Mounting accessories TA/TB/TC	J-23, 24
7	Accessories Y+PIN	J-31
8	Accessories I+PIN	J-31

No.	Accessories	Page
9	Floating joint MFC	V-01
10	Female rod ends PHS	V-04
11	Fitting PC (PISCO)	H-03
12	Speed controller JSC (PISCO)	H-14
13	Solenoid valve link seats VR/VH	J-22
14	Solenoid valve MVSC-260/300	A-14, 17
15	Sensor switch RCA+HV*	V-05
16	Protective bellows kit	—

## STANDARD CYLINDERS

**11**

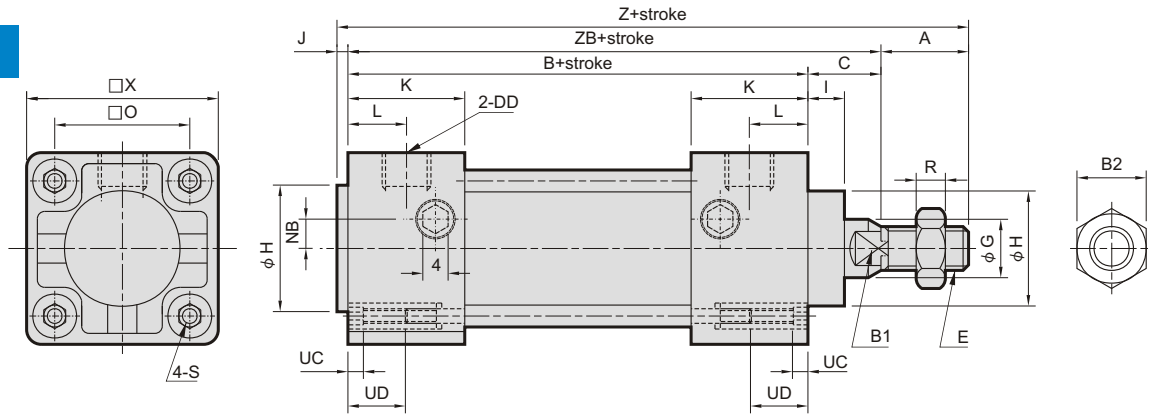

**21**

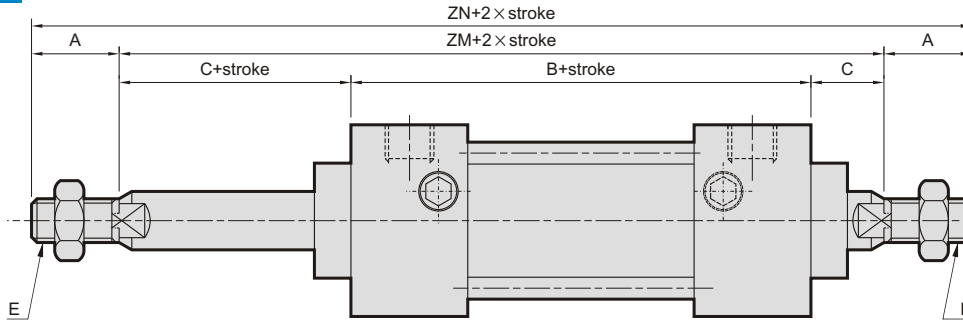

**27**

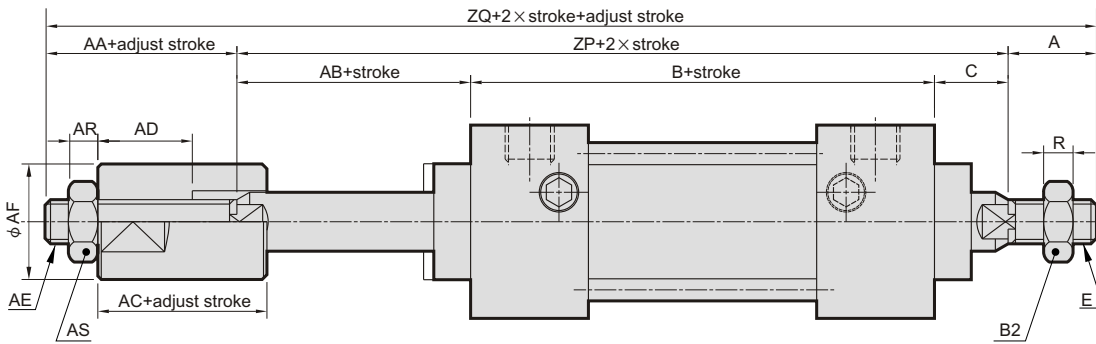

Code Tube I.D.	A	AA	AB	AC	AD	AE	AF	AR	AS	B	B1	B2	C	DD	E	G	H	I	J	K	L	NB	O	R
40	30	21	18	12	7	M12×1.25	30	7	19	84	14	22	21	Rc1/4	M14×1.5	16	32	11	3	26	13	8	40.5	8
50	35	23	18	15	10	M16×1.5	40	8	24	90	17	27	23	Rc3/8	M18×1.5	20	40	11	3	28	14	0	48	11
63	35	23	18	15	10	M16×1.5	40	8	24	98	17	27	23	Rc3/8	M18×1.5	20	40	11	3	30	15	0	59	11
80	40	33	24	20	14	M22×1.5	50	13	32	116	22	32	31	Rc1/2	M22×1.5	25	45	15	4	34	17	0	74	13
100	40	33	24	20	14	M22×1.5	50	13	32	126	27	36	32	Rc1/2	M26×1.5	30	52	15	5	37	18.5	0	90	14

Code Tube I.D.	S	UC	UD	X	Z	ZB	ZM	ZN	ZP	ZQ
40	M8×1.25	4	12	58	138	105	126	186	123	174
50	M8×1.25	4	12	66	151	113	136	206	131	189
63	M8×1.25	4	12	80	159	121	144	214	139	197
80	M12×1.75	4	15	100	191	147	178	258	171	244
100	M12×1.75	4	15	118	203	158	190	270	182	255

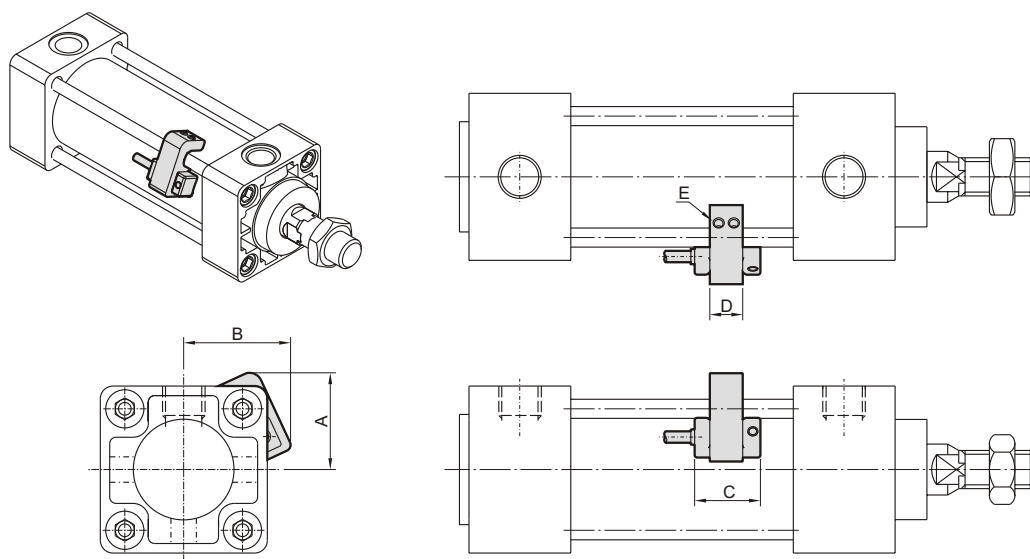

Code Tube I.D.	Sensor switch	Hold	A	B	C	D	E
40	RCA	HV2	36	41	26	13	M4 × 10L
50	RCA	HV2	38	43	26	13	M4 × 10L
63	RCA	HV2	46	49	26	13	M4 × 10L
80	RCA	HV4	52	55	26	13	M4 × 10L
100	RCA	HV4	59	62	26	13	M4 × 10L
125	RCA	PM14	—	—	26	12	M4 × 10L
150	RCA	PM16	—	—	26	12	M4 × 10L
200	RCA	HA5	—	—	26	15	M4 × 10L

## ■ Mounting accessories

### LB

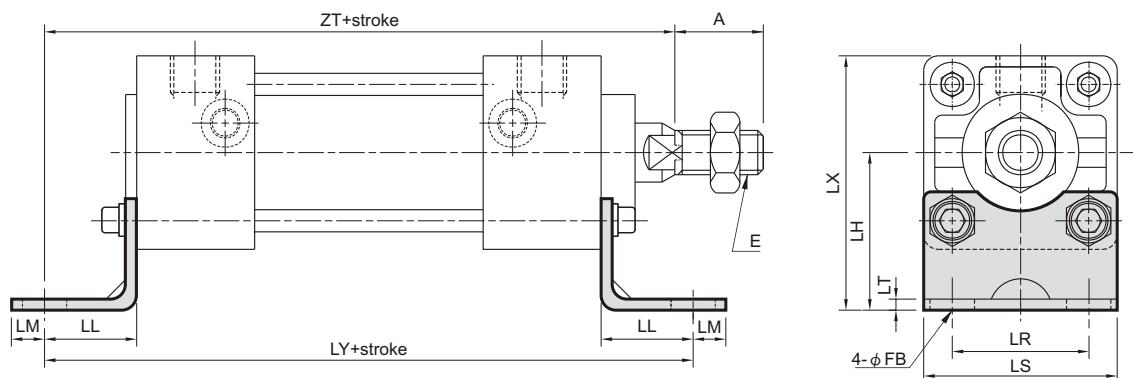

Code Tube I.D.	A	E	FB	LH	LL	LM	LR	LS	LT	LX	LY	ZT
40	30	M14 × 1.5	9	40	27	13	42	58	3.2	69	138	132
50	35	M18 × 1.5	9	45	27	13	50	66	3.2	78	144	140
63	35	M18 × 1.5	11.5	50	34	16	59	80	4.5	90	166	155
80	40	M22 × 1.5	14	65	44	16	76	100	6	115	204	191
100	40	M26 × 1.5	14	75	43	17	92	118	6	134	212	201

### FA

Note: This type is applied to the cylinder which the stroke is within 500mm.  
If the stroke is over 500mm, we advise to choose the FAC type.

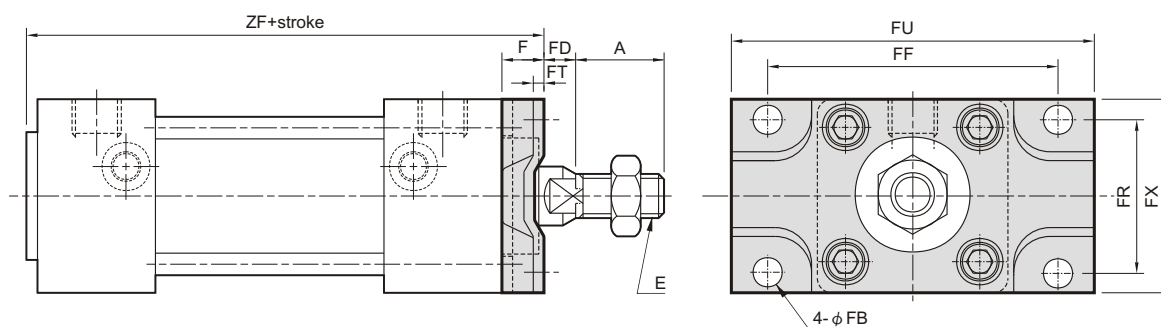

Code Tube I.D.	A	E	F	FB	FD	FF	FR	FT	FU	FX	ZF
40	30	M14×1.5	12	9	9	80	42	3.2	100	58	99
50	35	M18×1.5	12	9	11	90	50	3.2	110	66	105
63	35	M18×1.5	15	11.5	8	105	59	4.5	130	80	116

### FAC

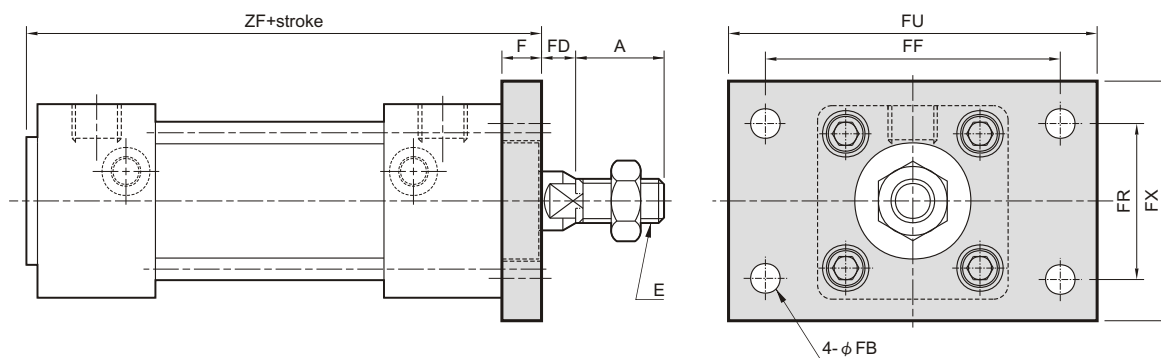

Code Tube I.D.	A	E	F	FB	FD	FF	FR	FU	FX	ZF
40	30	M14×1.5	12	9	9	80	42	100	65	99
50	35	M18×1.5	12	9	11	90	50	110	73	105
63	35	M18×1.5	15	11.5	8	105	59	130	84	116
80	40	M22×1.5	18	14	13	130	76	160	108	138
100	40	M26×1.5	18	14	14	150	92	180	124	149



### FB

Note: This type is applied to the cylinder which the stroke is within 500mm.  
If the stroke is over 500mm, we advise to choose the FBC type.

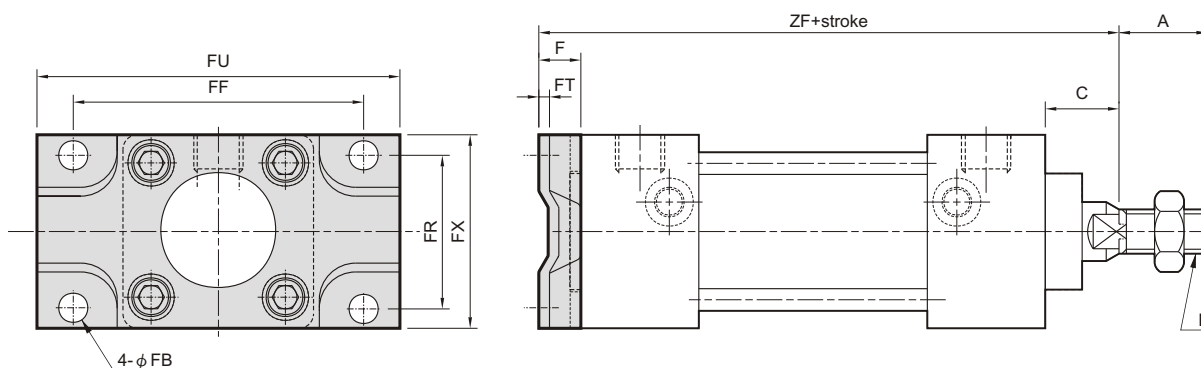

Code Tube I.D.	A	E	C	F	FB	FF	FR	FT	FU	FX	ZF
40	30	M14×1.5	21	12	9	80	42	3.2	100	58	117
50	35	M18×1.5	23	12	9	90	50	3.2	110	66	125
63	35	M18×1.5	23	15	11.5	105	59	4.5	130	80	136

### FBC

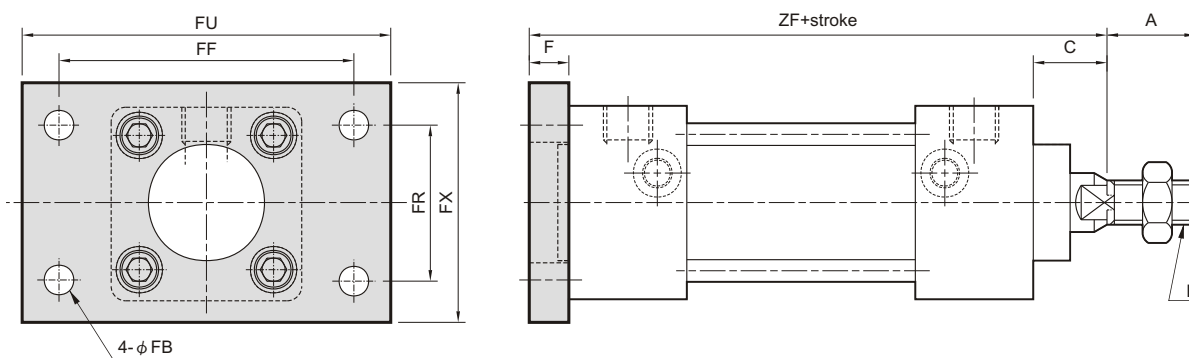

Code Tube I.D.	A	C	E	F	FB	FF	FR	FU	FX	ZF
40	30	21	M14×1.5	12	9	80	42	100	65	117
50	35	23	M18×1.5	12	9	90	50	110	73	125
63	35	23	M18×1.5	15	11.5	105	59	130	84	136
80	40	31	M22×1.5	18	14	130	76	160	108	165
100	40	32	M26×1.5	18	14	150	92	180	124	176

### CA

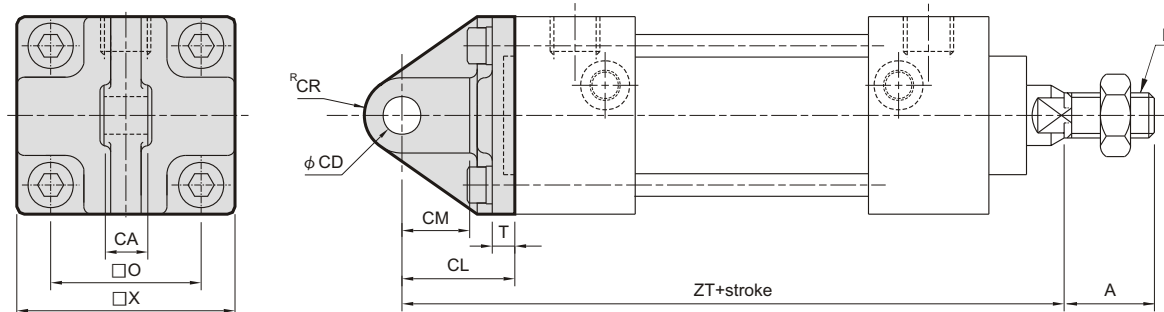

Code Tube I.D.	A	CA	CD	CL	CM	CR	E	O	T	X	ZT
40	30	15 <sup>-0.1 -0.3</sup>	10 <sup>H10</sup>	30	18	10	M14 × 1.5	40.5	5	58	135
50	35	18 <sup>-0.1 -0.3</sup>	12 <sup>H10</sup>	35	22	12	M18 × 1.5	48	5	66	148
63	35	25 <sup>-0.1 -0.3</sup>	16 <sup>H10</sup>	40	27	16	M18 × 1.5	59	5	80	161
80	40	31.5 <sup>-0.1 -0.3</sup>	20 <sup>H10</sup>	48	30	20	M22 × 1.5	74	7.5	100	195
100	40	35.5 <sup>-0.1 -0.3</sup>	25 <sup>H10</sup>	58	38	25	M26 × 1.5	90	7.5	118	216

### CB

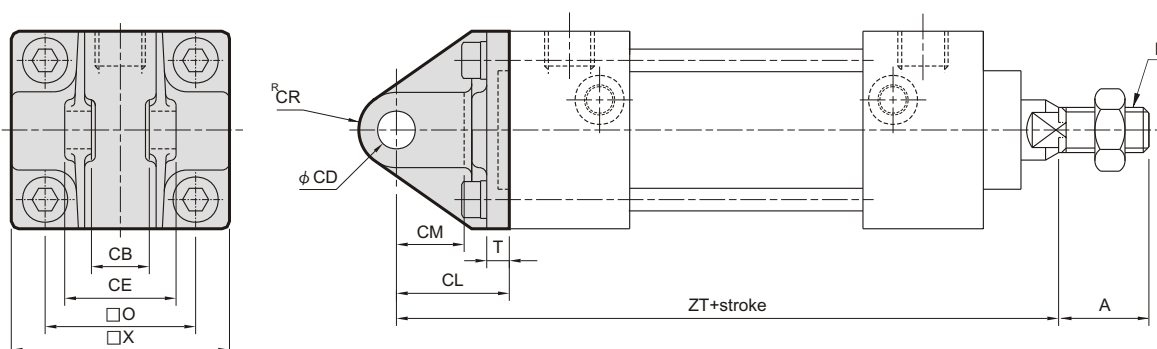

Code Tube I.D.	A	CB	CD	CE	CL	CM	CR	E	O	T	X	ZT
40	30	15 <sup>+0.3 +0.1</sup>	10 <sup>H10</sup>	31.5	30	18	10	M14 × 1.5	40.5	5	58	135
50	35	18 <sup>+0.3 +0.1</sup>	12 <sup>H10</sup>	40.5	35	22	12	M18 × 1.5	48	5	66	148
63	35	25 <sup>+0.3 +0.1</sup>	16 <sup>H10</sup>	53	40	27	16	M18 × 1.5	59	5	80	161
80	40	31.5 <sup>-0.3 +0.1</sup>	20 <sup>H10</sup>	60.8	48	30	20	M22 × 1.5	74	7.5	100	195
100	40	35.5 <sup>-0.3 +0.1</sup>	25 <sup>H10</sup>	69	58	38	25	M26 × 1.5	90	7.5	118	216

### TC

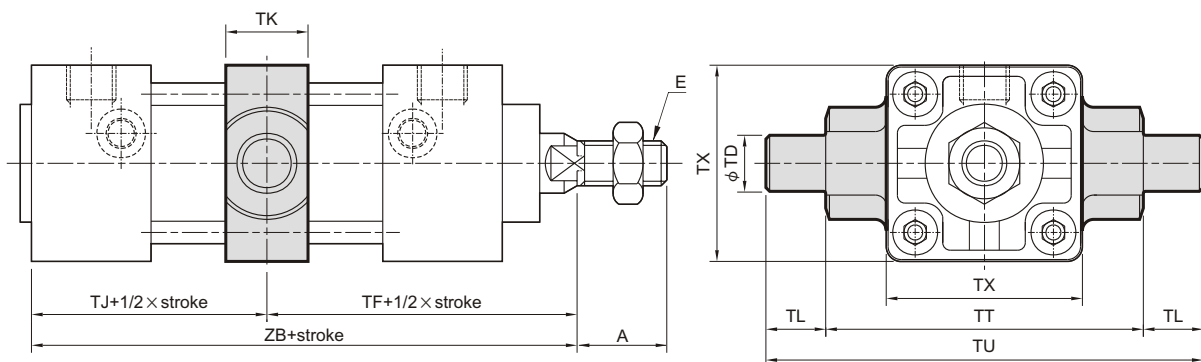

Code Tube I.D.	A	E	TD	TF	TJ	TK	TL	TT	TU	TX	ZB
40	30	M14 x 1.5	15 <sup>ø8</sup>	63	42	22	16	85	117	58	105
50	35	M18 x 1.5	15 <sup>ø8</sup>	68	45	22	16	95	127	67	113
63	35	M18 x 1.5	18 <sup>ø8</sup>	72	49	28	19	110	148	82	121
80	40	M22 x 1.5	25 <sup>ø8</sup>	89	58	34	26	140	192	102	147
100	40	M26 x 1.5	25 <sup>ø8</sup>	95	63	40	26	162	214	122	158

### TA

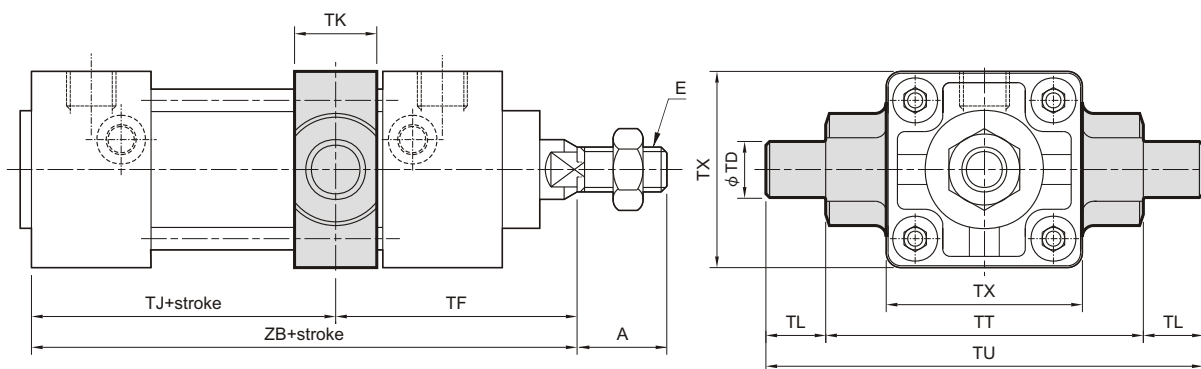

Code Tube I.D.	A	E	TD	TF	without magnet		magnet		TK	TL	TT	TU	TX
					TJ	ZB	TJ	ZB					
40	30	M14 x 1.5	15 <sup>ø8</sup>	60	45	105	75	135	22	16	85	117	58
50	35	M18 x 1.5	15 <sup>ø8</sup>	64	49	113	79	143	22	16	95	127	67
63	35	M18 x 1.5	18 <sup>ø8</sup>	69	52	121	82	151	28	19	110	148	82
80	40	M22 x 1.5	25 <sup>ø8</sup>	85	62	147	102	187	34	26	140	192	102
100	40	M26 x 1.5	25 <sup>ø8</sup>	92	66	158	106	198	40	26	162	214	122

### TB

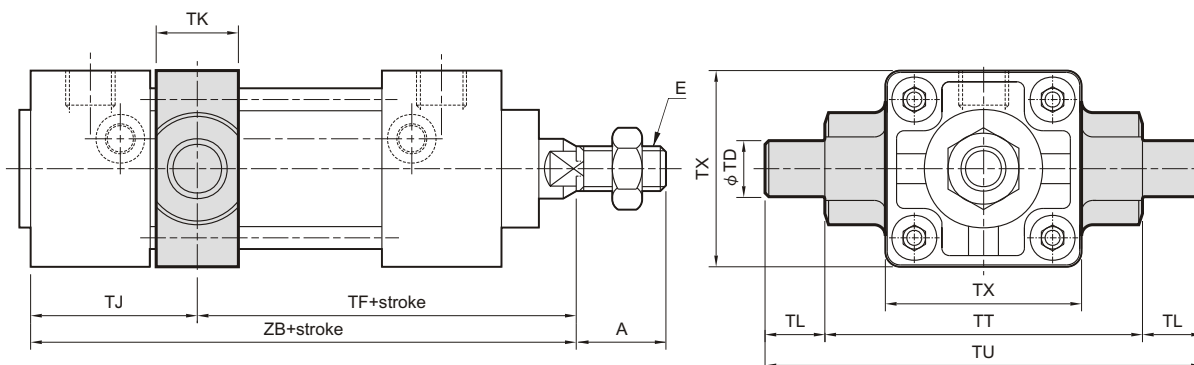

Code Tube I.D.	A	E	TD	without magnet		magnet		TJ	TK	TL	TT	TU	TX
				TF	ZB	TF	ZB						
40	30	M14 × 1.5	15 <sup>øB</sup>	66	105	96	135	39	22	16	85	117	58
50	35	M18 × 1.5	15 <sup>øB</sup>	72	113	102	143	41	22	16	95	127	67
63	35	M18 × 1.5	18 <sup>øB</sup>	75	121	105	151	46	28	19	110	148	82
80	40	M22 × 1.5	25 <sup>øB</sup>	93	147	133	187	54	34	26	140	192	102
100	40	M26 × 1.5	25 <sup>øB</sup>	98	158	138	198	60	40	26	162	214	122

### SDS

Stroke over 1000mm

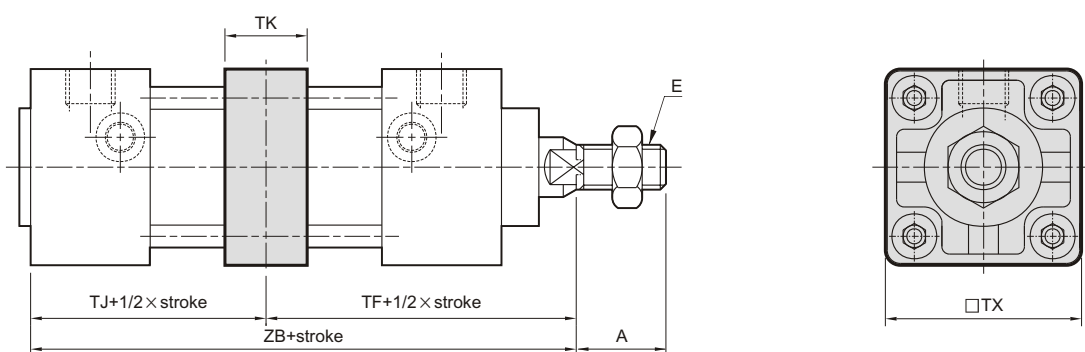

Code Tube I.D.	A	E	TF	TJ	TK	TX	ZB
40	30	M14 × 1.5	63	42	22	58	105
50	35	M18 × 1.5	68	45	22	67	113
63	35	M18 × 1.5	72	49	28	82	121
80	40	M22 × 1.5	89	58	34	102	147
100	40	M26 × 1.5	95	63	40	122	158

### 11

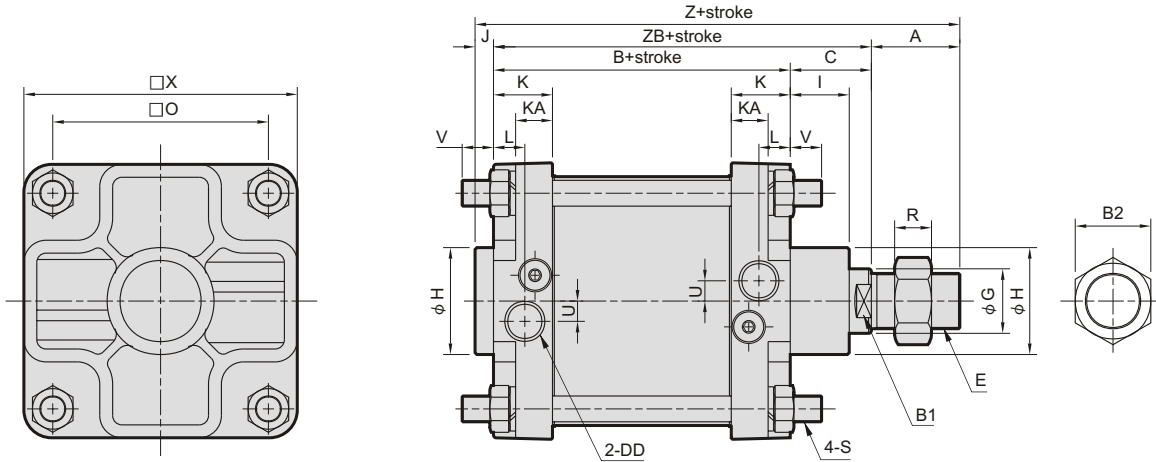

Code Tube I.D.	A	B	B1	B2	C	DD	E	G	H	I	J	K	KA	L	O	R	S	U	V	X	Z	ZB
125	45	136	30	41	47	PT 1/2	M30 x 1.5	35	58	32	10	32	20	17	117	15	M14 x 1.5	11	20	150	238	183
150	50	153	36	41	47	PT 1/2	M30 x 1.5	40	60	32	8	40.5	25	24.5	134	15	M16 x 1.5	12	26	175	258	200
200	63	154	46	70	67	PT 3/4	M45 x 1.5	50	74	35	8	42	25	24	182	27	M20 x 1.5	12	18	226	292	221

### LB

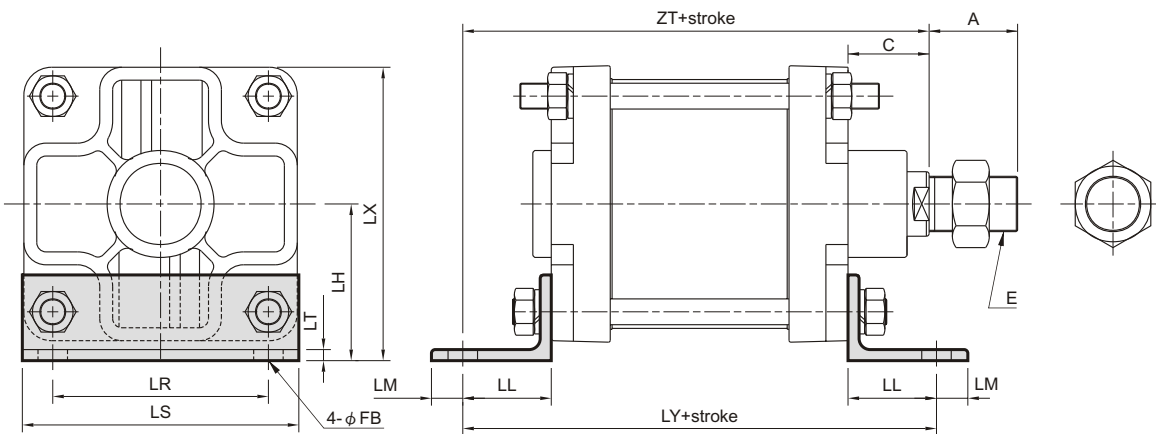

Code Tube I.D.	A	E	FB	LH	LL	LM	LR	LS	LT	LX	LY	ZT
125	45	M30 x 1.5	16	85	48	17	117	150	6	162	232	231
150	50	M30 x 1.5	18	96.5	55	20	134	175	9	184	263	255
200	63	M45 x 1.5	24	132	60	30	150	226	10	245	274	281

### FAC

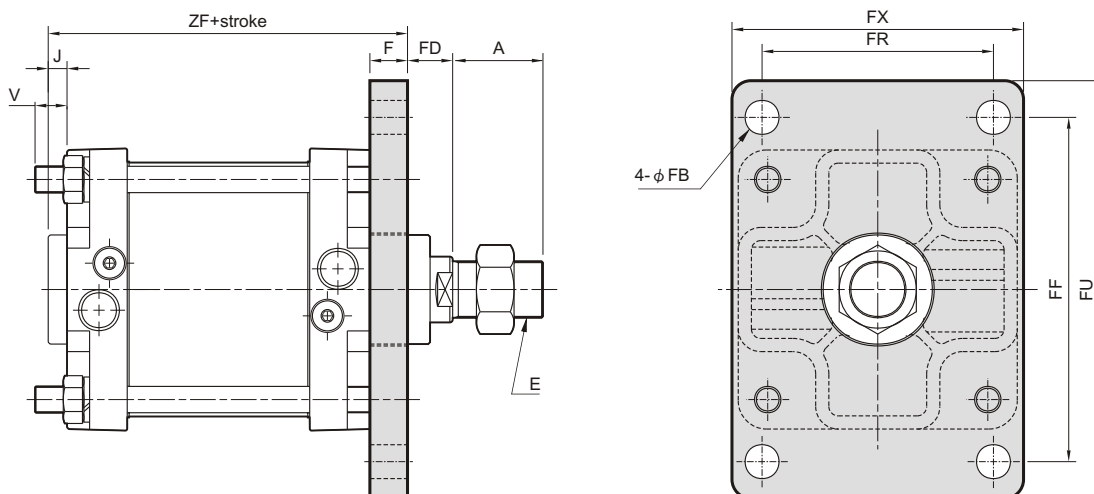

Code Tube I.D.	A	E	F	FB	FD	FF	FR	FU	FX	J	V	ZF
125	45	M30×1.5	20	18	27	183	123	222	155	10	20	166
150	50	M30×1.5	20	18	27	230	134	275	185	8	26	181
200	63	M45×1.5	25	24	42	280	150	335	225	8	11	187

### FBC

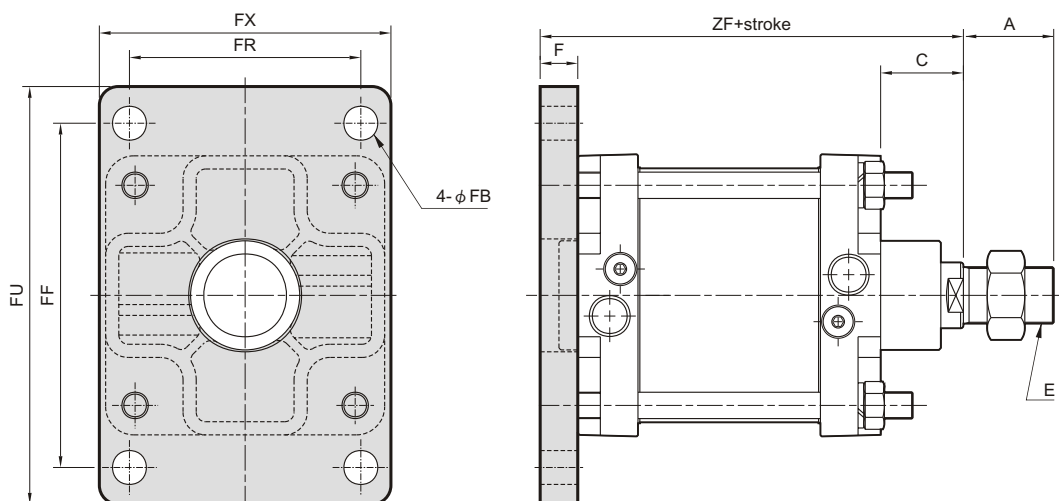

Code Tube I.D.	A	C	E	F	FB	FF	FR	FU	FX	ZF
125	45	47	M30×1.5	20	18	183	123	222	155	203
150	50	47	M30×1.5	20	18	230	134	275	185	220
200	63	67	M45×1.5	25	24	280	150	335	225	246

CA

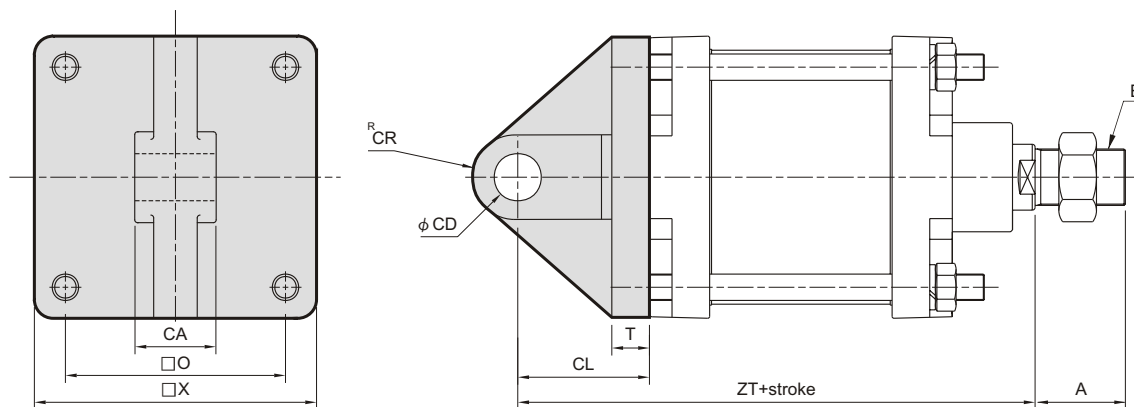

Code Tube I.D.	A	CA	CD	CL	CR	E	O	T	X	ZT
125	45	43 <sup>-0.1</sup> <sub>-0.3</sub>	25 <sup>H10</sup>	65	24	M30 × 1.5	117	15	150	248
150	50	40 <sup>-0.1</sup> <sub>-0.3</sub>	30 <sup>H10</sup>	78	27.5	M30 × 1.5	134	20	175	278
200	63	50 <sup>-0.1</sup> <sub>-0.3</sub>	40 <sup>H10</sup>	85	40	M45 × 1.5	182	25	226	306

CB

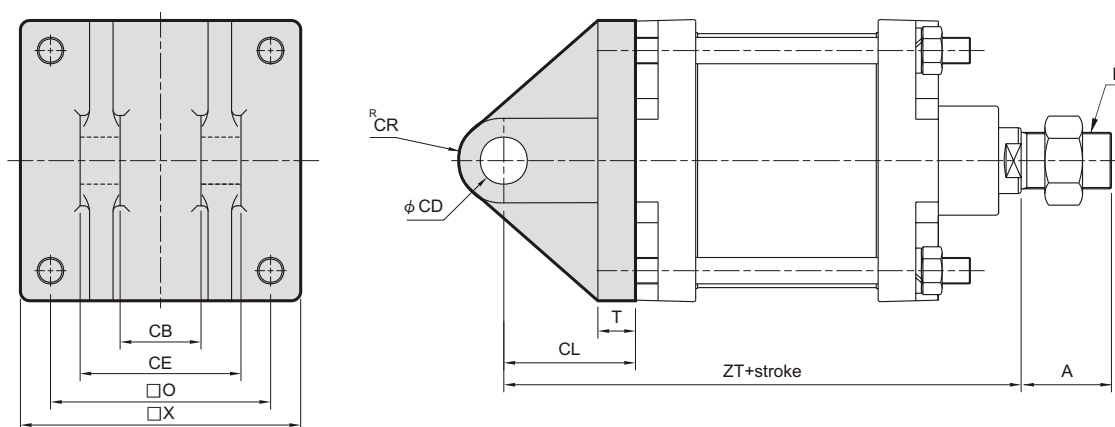

Code Tube I.D.	A	CB	CD	CE	CL	CR	E	O	T	X	ZT
125	45	43 <sup>+0.3</sup> <sub>+0.1</sub>	25 <sup>H10</sup>	85.5	70	24	M30 × 1.5	117	20	150	253
150	50	40 <sup>+0.3</sup> <sub>+0.1</sub>	30 <sup>H10</sup>	90	78	27.5	M30 × 1.5	134	20	175	278
200	63	50 <sup>+0.3</sup> <sub>+0.1</sub>	40 <sup>H10</sup>	100	85	40	M45 × 1.5	182	25	226	306

### TC

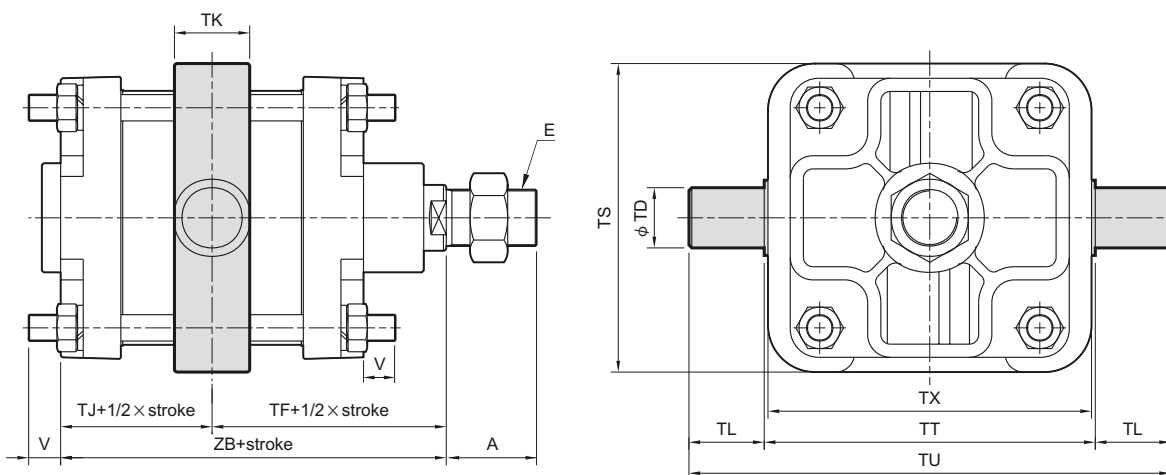

Code Tube I.D.	A	E	TD	TF	TJ	TK	TL	TS	TT	TU	TX	V	ZB
125	45	M30 x 1.5	32 <sup>øB</sup>	115	68	40	40	164	176	256	172	17	183
150	50	M30 x 1.5	35 <sup>øB</sup>	123.5	76.5	41	40	194	200	280	198	16	200
200	63	M45 x 1.5	45 <sup>øB</sup>	144	77	59	45	255	265	355	255	8.5	221

### TA

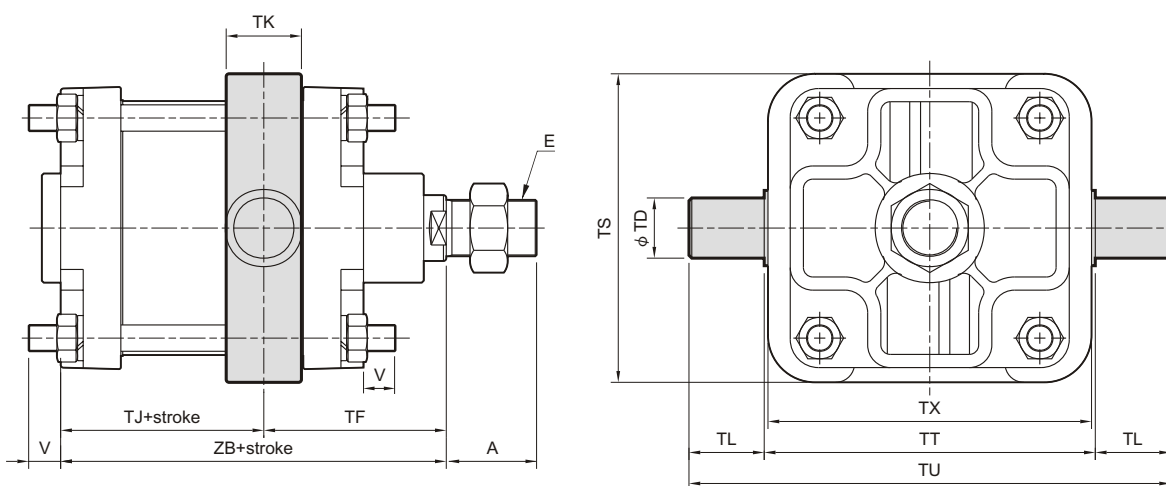

Code Tube I.D.	A	E	TD	TF	without magnet		magnet		TK	TL	TS	TT	TU	TX	V
					TJ	ZB	TJ	ZB							
125	45	M30 x 1.5	32 <sup>øB</sup>	100	83	183	129	229	40	40	164	176	256	172	17
150	50	M30 x 1.5	35 <sup>øB</sup>	109	91	200	137	246	41	40	194	200	280	198	16
200	63	M45 x 1.5	45 <sup>øB</sup>	139.5	81.5	221	125.5	265	59	45	255	265	355	255	8.5



**TB**

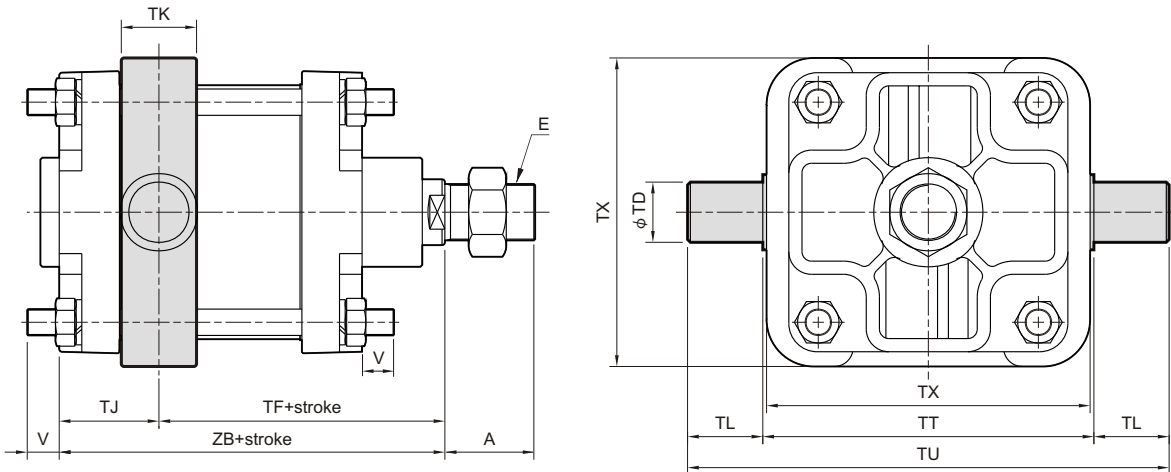

Code Tube I.D.	A	E	TD	without magnet		magnet		TJ	TK	TL	TS	TT	TU	TX	V
				TF	ZB	TF	ZB								
125	45	M30 × 1.5	32 <sup>øB</sup>	130	183	176	229	53	40	40	164	176	256	172	17
150	50	M30 × 1.5	35 <sup>øB</sup>	138	200	184	246	62	41	40	194	200	280	198	16
200	63	M45 × 1.5	45 <sup>øB</sup>	148.5	221	192.5	265	72.5	59	45	255	265	355	255	8.5

21

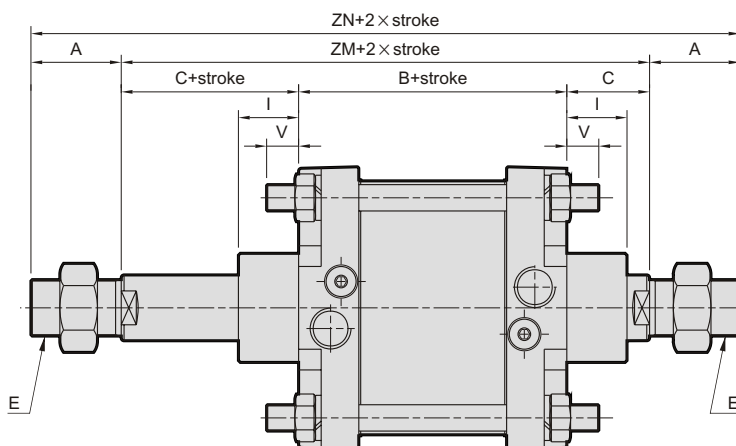

Code Tube I.D.	A	B	C	E	I	V	ZM	ZN
125	45	136	47	M30×1.5	32	20	230	320
150	50	153	47	M30×1.5	32	26	247	347
200	63	154	67	M45×1.5	35	18	288	414

27

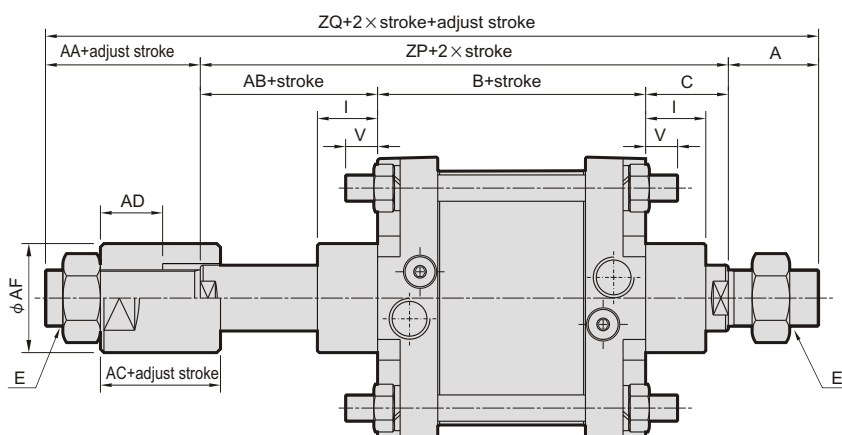

Code Tube I.D.	A	AA	AB	AC	AD	AF	B	C	E	I	V	ZM	ZN	ZP	ZQ
125	45	38	47	30	18	60	136	47	M30×1.5	32	20	230	320	230	313
150	50	38	47	30	18	60	153	47	M30×1.5	32	26	247	347	247	335
200	63	38	50	30	18	70	154	67	M45×1.5	35	18	288	414	271	372

STANDARD CYLINDERS

Y connector

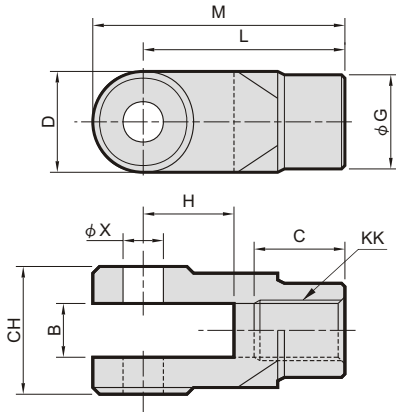

I connector

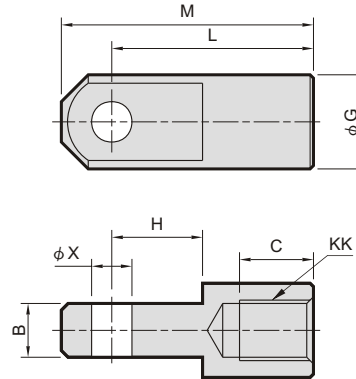

Code Tube I.D.	B		C		CH		D		G		H		KK		L		M		X <sup>H10</sup>
	Y	I	Y	I	Y	I	Y	I	Y	I	Y	I	Y	I	Y	I	Y	I	
40	16 <sup>+0.3</sup> <sub>+0.1</sub>	16 <sup>-0.1</sup> <sub>-0.3</sub>	25	20	38	/	26	/	$\phi 24$	$\phi 24$	25	25	M14 $\times$ 1.5	55	55	68	68	$\phi 12$ <sup>+0.07</sup> <sub>0</sub>	
50 63	16 <sup>+0.3</sup> <sub>+0.1</sub>	16 <sup>-0.1</sup> <sub>-0.3</sub>	27	22	38	/	30	/	$\phi 28$	$\phi 28$	27	27	M18 $\times$ 1.5	60	60	75	75	$\phi 12$ <sup>+0.07</sup> <sub>0</sub>	
80	28 <sup>+0.3</sup> <sub>+0.1</sub>	28 <sup>-0.1</sup> <sub>-0.3</sub>	32	27	55	/	38	/	$\phi 36$	$\phi 36$	32	32	M22 $\times$ 1.5	71	71	90	90	$\phi 18$ <sup>+0.07</sup> <sub>0</sub>	
100	30 <sup>+0.3</sup> <sub>+0.1</sub>	30 <sup>-0.1</sup> <sub>-0.3</sub>	35	30	59	/	42	/	$\phi 40$	$\phi 40$	38	38	M26 $\times$ 1.5	83	83	104	104	$\phi 20$ <sup>+0.08</sup> <sub>0</sub>	
125	32 <sup>+0.3</sup> <sub>+0.1</sub>	32 <sup>-0.1</sup> <sub>-0.3</sub>	35	40	76	/	58	/	$\phi 45$	$\phi 49$	38	32	M30 $\times$ 1.5	80	80	109	109	$\phi 20$ <sup>+0.08</sup> <sub>0</sub>	
150	40 <sup>+0.3</sup> <sub>+0.1</sub>	40 <sup>-0.1</sup> <sub>-0.3</sub>	35	40	84	/	54	/	$\phi 45$	$\phi 60$	39	32	M30 $\times$ 1.5	80	80	107	107	$\phi 25$ <sup>+0.08</sup> <sub>0</sub>	
200	50 <sup>+0.3</sup> <sub>+0.1</sub>	50 <sup>-0.1</sup> <sub>-0.3</sub>	67	67	100	/	85	/	$\phi 70$	$\phi 70$	54	44	M45 $\times$ 1.5	125	125	167.5	167.5	$\phi 40$ <sup>+0.1</sup> <sub>0</sub>	

Pin

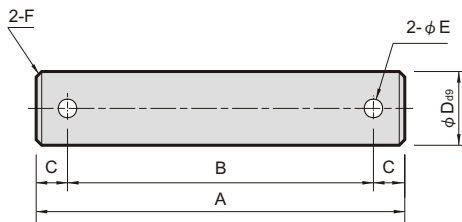

Order example

PIN – MCQA – 40 – Y – P

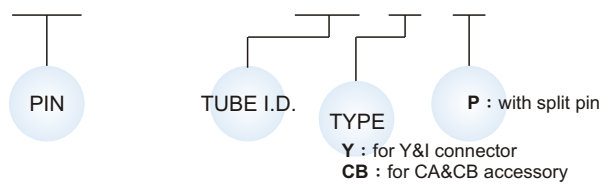

for Y & I connector

Code Tube I.D.	A	B	C	D <sup>d9</sup>	E	F	Split pin
40 63	57	46	5.5	$\phi 12$ <sup>-0.05</sup> <sub>-0.09</sub>	3.5	1.0	3.2 $\times$ 20L
80	78	64	7	$\phi 18$ <sup>-0.05</sup> <sub>-0.09</sub>	4	1.2	4 $\times$ 25L
100	87	70	8.5	$\phi 20$ <sup>-0.06</sup> <sub>-0.12</sub>	5	1.5	5 $\times$ 35L
125	100	83	8.5	$\phi 20$ <sup>-0.06</sup> <sub>-0.12</sub>	5	1.5	5 $\times$ 35L
150	112	95	8.5	$\phi 25$ <sup>-0.06</sup> <sub>-0.12</sub>	5	2.0	5 $\times$ 35L
200	115	105	5	$\phi 40$ <sup>-0.08</sup> <sub>-0.14</sub>	5	2.0	5 $\times$ 55L

for CA & CB

Code Tube I.D.	A	B	C	D <sup>d9</sup>	E	F	Split pin
40	48	37	5.5	$\phi 10$ <sup>-0.05</sup> <sub>-0.09</sub>	3.5	1.0	3.2 $\times$ 20L
50	57	46	5.5	$\phi 12$ <sup>-0.05</sup> <sub>-0.09</sub>	3.5	1.0	3.2 $\times$ 20L
63	72	58	7	$\phi 16$ <sup>-0.05</sup> <sub>-0.09</sub>	4	1.2	4 $\times$ 25L
80	87	70	8.5	$\phi 20$ <sup>-0.06</sup> <sub>-0.12</sub>	5	1.5	5 $\times$ 35L
100	93	76	8.5	$\phi 25$ <sup>-0.06</sup> <sub>-0.12</sub>	5	1.5	5 $\times$ 35L
125	112	95	8.5	$\phi 25$ <sup>-0.06</sup> <sub>-0.12</sub>	5	1.5	5 $\times$ 35L
150	119	102	8.5	$\phi 30$ <sup>-0.06</sup> <sub>-0.12</sub>	5	2.0	5 $\times$ 40L
200	115	105	5	$\phi 40$ <sup>-0.08</sup> <sub>-0.14</sub>	5	2.0	5 $\times$ 55L

## STANDARD CYLINDERS

### Order example

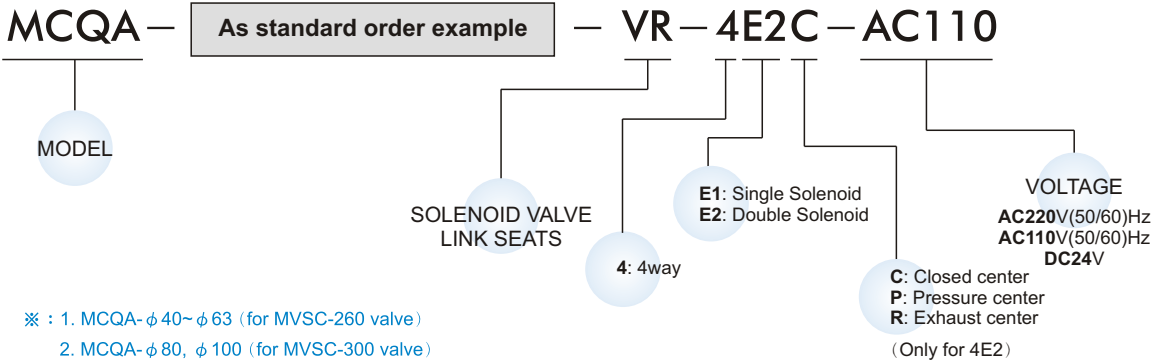

**VR**

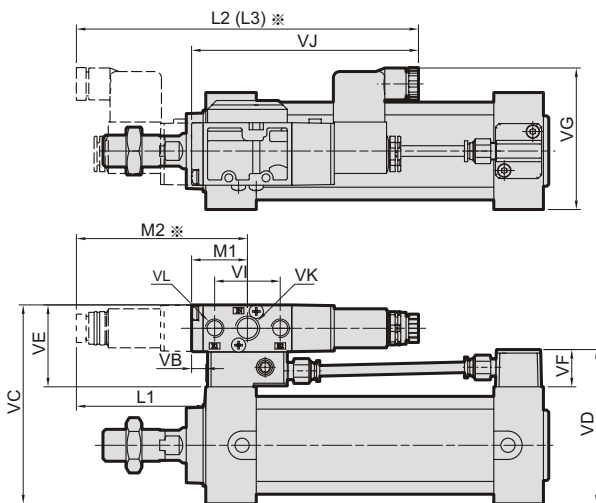

**VH**

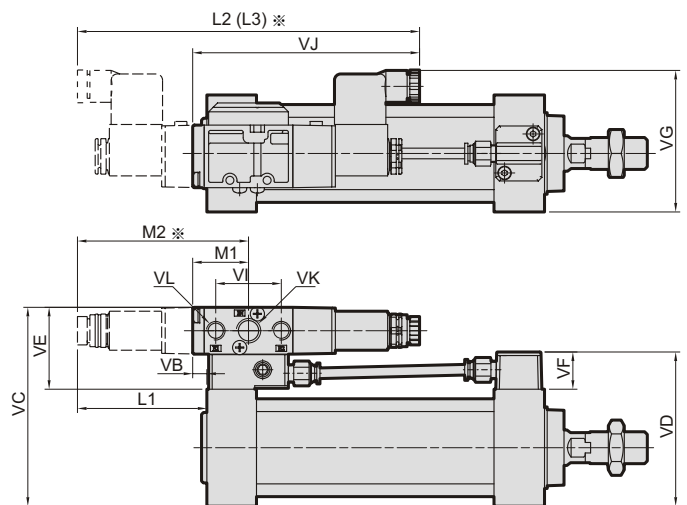

Code Tube I.D.	L1	L2	L3	M1	M2	VB	VC	VD	VE	VF	VG	VI	VJ	VK	VL	Valve type
40	77.5	199	220	31.5	99.5	9.5	104.2	79	46.2	21	76	37	131	Rc1/4	Rc1/8	MVSC-260
50	78.5	199	220	31.5	99.5	8.5	112.2	87	46.2	21	80	37	131	Rc1/4	Rc1/8	MVSC-260
63	79.5	199	220	31.5	99.5	7.5	126.2	101	46.2	21	87	37	131	Rc1/4	Rc1/8	MVSC-260
80	80.5	222	275	45	111	14.5	159	128	59	28	90	52	156	Rc3/8	Rc3/8	MVSC-300
100	78.5	222	275	45	111	12.5	179	146	59	28	104	52	156	Rc3/8	Rc3/8	MVSC-300

※ L2 for 4E2 size, L3 for 4E2C,P,R size, M2 for 4E2 and 4E2C,P,R size.