



Features

- Long stroke type of the anti-turn accuracy, improved by integrating the guides and cylinder.
- Linear bush bearing type available for high accuracy in the high speed work.
- On the link bar at the top, Many thread holes for mounting attachments are provided for easy mounting.
- Lift type of long stroke is available by replacing the link bar with table plate.
- Magnetic as standard.

Specification

Model	MCGA					
Model	 (for $\phi 80$ stroke over 100 mm)					
Acting type	Double acting					
Tube I.D.(mm)	20	32	40	50	63	80
Port size (Rc)	1/8	1/4 [1/8]	1/4 [1/8]	3/8 [1/4]	3/8	3/8
Medium	Air					
Operating pressure range	0.1~1 MPa					
Proof pressure	1.5 MPa					
Ambient temperature	-5~+60°C (No freezing)					
Cushion	With rubber cushion pad					
Available speed range	50~500mm/sec					
Lubrication	Not required					
Sensor switch (※)	RCB					

Order example

MCGA-23-20-50-G

MODEL

TUBE I.D.

STROKE

PURPOSE / TYPE OF BEARING

Code	Purpose / Type of bearing
23	Push / Linear bush bearing
63	Push / Slide bearing

PORT THREAD
Blank: Rc thread
G: G thread
NPT: NPT thread

□ :For MCGA-23 stroke~ 30st to 100st

※ RCB specification, please refer to page V-07.

Table for standard stroke

Series variety	Bearing type	Tube I.D.	Stroke (mm)									
			30	50	75	100	200	300	400	500	600	700
MCGA 23	Linear bush bearing	$\phi 20$	□	□	□	□	□	□	□	□	□	□
		$\phi 32$	□	□	□	□	□	□	□	□	□	□
		$\phi 40$	□	□	□	□	□	□	□	□	□	□
		$\phi 50$	□	□	□	□	□	□	□	□	□	□
		$\phi 63$	□	□	□	□	□	□	□	□	□	□
		$\phi 80$	□	□	□	□	□	□	□	□	□	□
MCGA 63	Slide bearing	$\phi 20$	□	□	□	□	□	□	□	□	□	□
		$\phi 32$	□	□	□	□	□	□	□	□	□	□
		$\phi 40$	□	□	□	□	□	□	□	□	□	□
		$\phi 50$	□	□	□	□	□	□	□	□	□	□
		$\phi 63$	□	□	□	□	□	□	□	□	□	□
		$\phi 80$	□	□	□	□	□	□	□	□	□	□

● Stroke out of specification is also available.

● Please consult us if stroke exceed 700mm.

Capacity graph

Capacity for the use as a pusher~

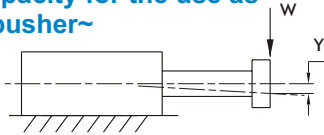

MCGA-23 / MCGA-63, deflection and allowable top load.

- In the actual operation, load at the top should be below the allowable top load.
- Y – Deflection
- W – Allowable top load

MCGA-23... φ 20

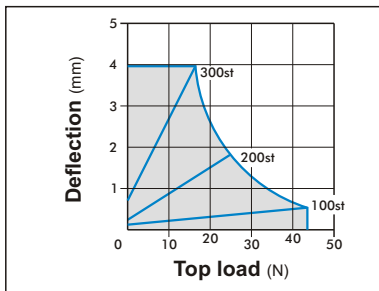

MCGA-23... φ 32

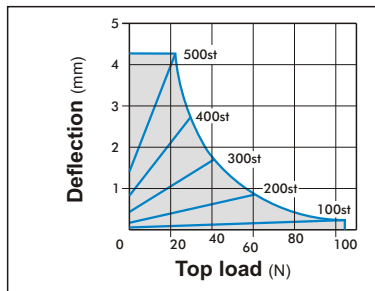

MCGA-23... φ 40

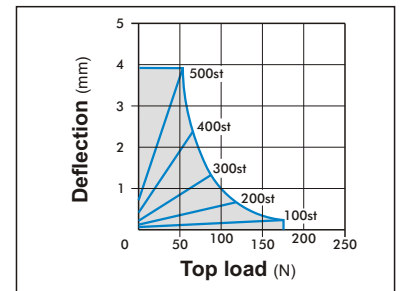

MCGA-23... φ 50

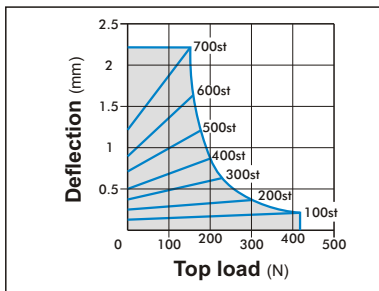

MCGA-23... φ 63

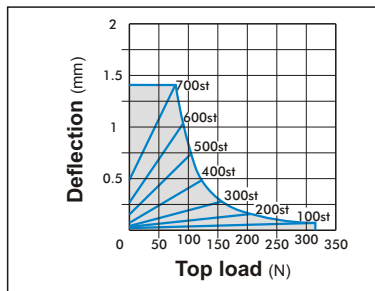

MCGA-23... φ 80

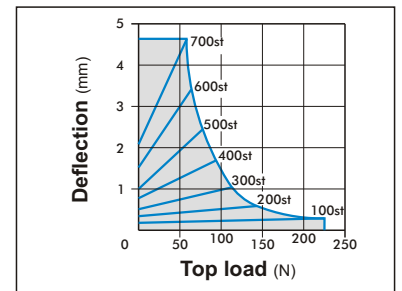

MCGA-63... φ 20

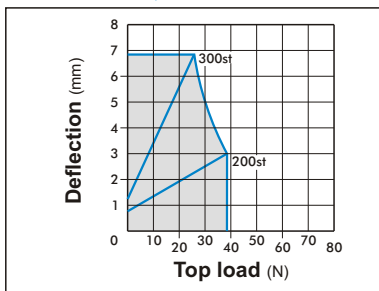

MCGA-63... φ 32

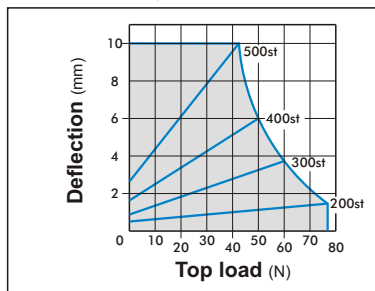

MCGA-63... φ 40

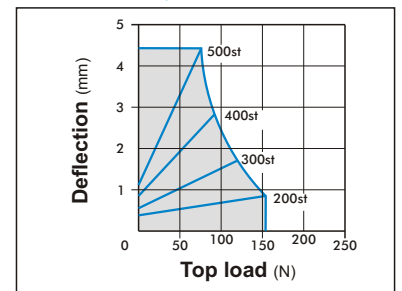

MCGA-63... φ 50

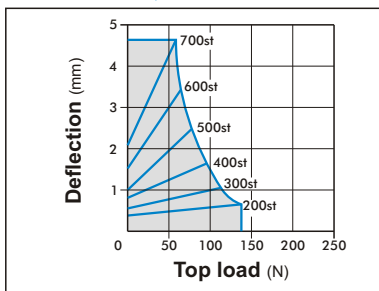

MCGA-63... φ 63

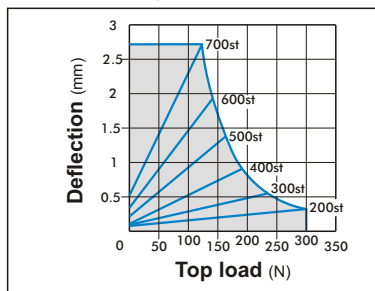

MCGA-63... φ 80

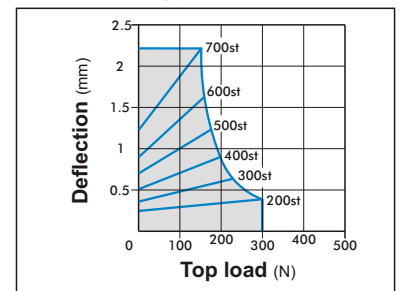

TWIN-GUIDE CYLINDER

mindman

MCGA-23/MCGA-63

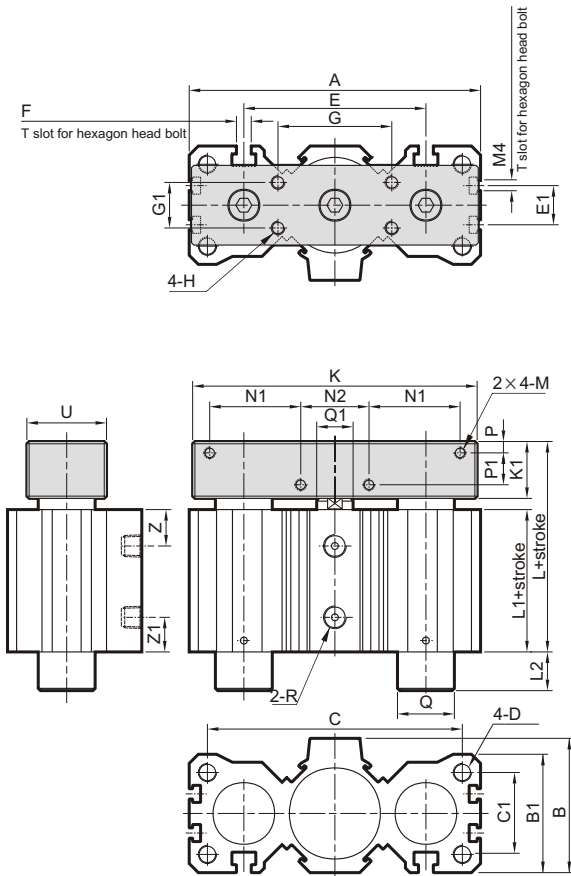

MCGA-63 ~For tube I.D. $\phi 80$, stroke 100st to 700st

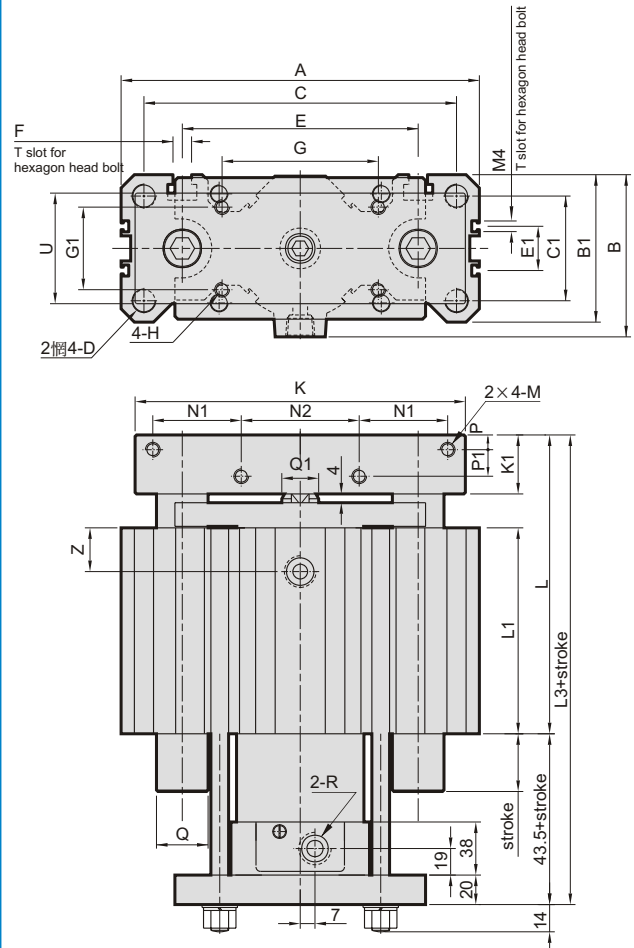

MCGA-23/MCGA-63 Tube I.D. $\phi 63, \phi 80$: only for MCGA-63 type

Code Tube I.D.	A	B	B1	C	C1	D	E	E1	F	G	G1	H	K	K1	L	L1	L2	M	N1	N2	P	P1	Q	Q1	R	U	Z	Z1	
20	75	34	32	63	20	M5×0.8×15dp	45	-	M4	32	16	M5×0.8×10dp	75	15	54	36	18	M4×0.7×8dp	22.5	20	4	6	$\phi 8$	$\phi 10$	Rc1/8	25	11	10	
32	106	51.5	45	90	30	M8×1.25×20dp	63	-	M6	40	18	M6×1.0×12dp	100	20	66.5	41.5	29.5	M5×0.8×10dp	32	25	5	9	$\phi 13(\phi 12)$	$\phi 16$	Rc1/4	$\frac{1}{8}$	30	12	12
40	128	59	52	112	36	M8×1.25×20dp	80	-	M6	50	20	M6×1.0×12dp	125	25	81	51	30	M5×0.8×10dp	40	30	5	14	$\phi 16$	$\phi 16$	Rc1/4	$\frac{1}{8}$	35	16	16.5
50	150	69	62	132	45	M10×1.5×25dp	100	20	M8	63	25	M8×1.25×16dp	140	30	87	52	39	M6×1.0×12dp	37.5	50	6	16	$\phi 20$	$\phi 20$	Rc3/8	$\frac{1}{4}$	40	16	17.5
63	180	87	78	156	53	M12×1.75×30dp	118	25	M10	80	40	M10×1.5×20dp	175	35	100	60	66	M8×1.25×16dp	47.5	60	9	16	$\phi 25$	$\phi 20$	Rc3/8		60	17.5	21
80	243	110	100	212	71	M16×2.0×40dp	160	30	M12	106	56	M10×1.5×20dp	224	40	110.5	62.5	103	M10×1.5×20dp	60	80	10	18	$\phi 35$	$\phi 25$	Rc3/8		75	22	19.5

□ :For MCGA-23 stroke 30st to 100st
() :For MCGA-63 type

MCGA-63 ~Tube I.D. $\phi 80$, stroke 200st to 700st

Code Tube I.D.	A	B	B1	C	C1	D	E	E1	F	G	G1	H	K	K1	L	L1	L3	M	N1	N2	P	P1	Q	Q1	R	U	Z	Z1
80	243	110	100	212	71	M16×2.0×40dp	160	30	M12	106	56	M10×1.5×20dp	224	40	213	150	256.5	M10×1.5×20dp	60	80	10	18	$\phi 35$	$\phi 25$	3/8	75	40	