

# MCJT Multiple position $\phi 12\sim\phi 100$

## COMPACT CYLINDERS

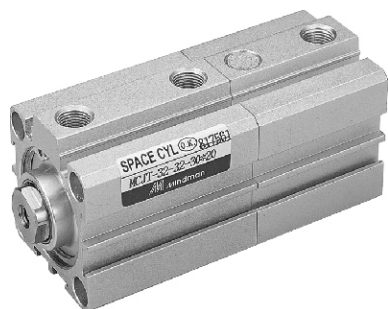

### Specification

Model		MCJT									
Acting type		Double acting / Single acting				Double acting					
Tube I.D. (mm)		12	16	20	25	32	40	50	63	80	100
Port size		M5 $\times$ 0.8			Rc1/8		Rc1/4		Rc3/8		
Medium		Air									
Operating pressure (MPa)	Double acting	0.05~1		0.03~1		0.02~1					
	Single acting	0.2~1		0.15~1		0.1~1		—			
Proof pressure		1.5 MPa									
Ambient temperature		-5~+60°C (No freezing)									
Available speed range		50~500 mm/sec									
Sensor switch (※)		RCB, RCE, RCE1									

※ RCB, RCE, RCE1 specification, please refer to page V-07, V-09.

### Order example

MCJT - 32 - 40 - 10  $\times$  25 M - G

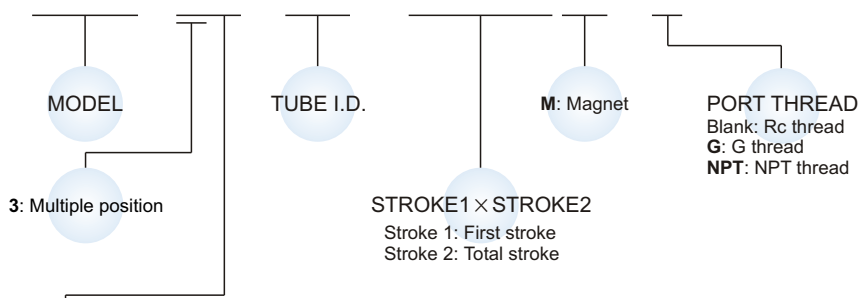

STYLE:

Code	Symbol	Description
3 1		Double acting / Male thread
3 2		Double acting / Female thread
3 5		Single acting / Normally returned male thread
3 6		Single acting / Normally returned female thread

※Order example for special specification, refer to page J-03.

### Double acting - Table for standard stroke

Tube I.D.	Stroke (mm)	Max. stroke
$\phi 12, \phi 16$	5, 10, 15, 20, 25, 30	300
$\phi 20, 25, 32$ $\phi 40, 50, 63$	5, 10, 15, 20, 25, 30, 35, 40, 45, 50	300
$\phi 80\sim 100$	5, 10, 15, 20, 25, 30, 35, 40, 45, 50	125

- Stroke out of specification is also available.
- Please consult us if stroke out of specification.

### Single acting - Table for standard stroke

Tube I.D.	Stroke (mm)
$\phi 12, 16, 20, 25, 32, 40$	5, 10
$\phi 50$	10, 20



# MCJT Multiple position Inside structure & Parts list

## COMPACT CYLINDERS



Mindman

### Double acting

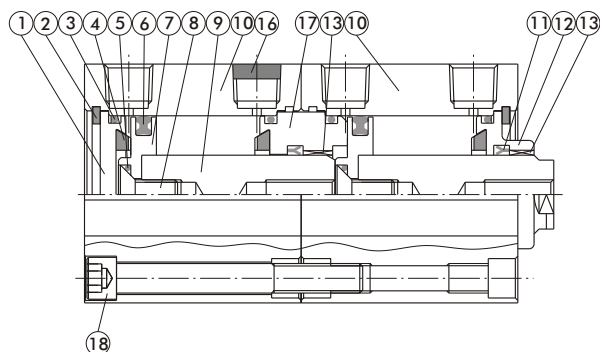

### Single acting normally returned

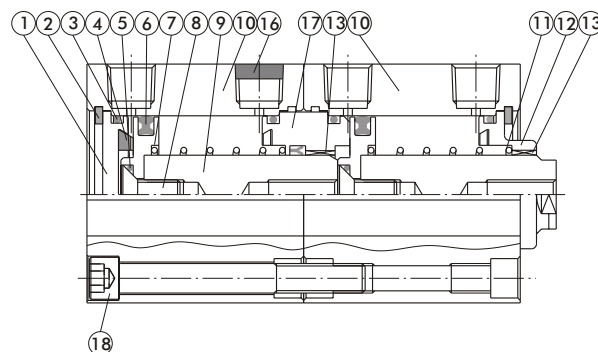

### Seal kit

Acting type	Rod packing		Piston packing		Cover ring	Piston gasket
	Double action normally extended	Normally returned	Double action	Single action	Double action single action	Double action single action
Qty.	2	1	2	2	4	2
12	KSYR-6	KSYR-6	OPA-12	OPA-12	S-12	d4 × w1
16	KSYR-8	KSYR-8	OPA-16	OPA-16	S-14	d6 × w1
20	KSYR-10	KSYR-10	OPA-20	OPA-20	S-18	d6 × w1
25	KSYR-12	KSYR-12	OPA-25	OPA-25	S-22	d8 × w1
32	KSYR-16	KSYR-16	OPA-32	OPA-32	d28 × w2	S-9
40	KSYR-16	KSYR-16	OPA-40	OPA-40	S-36	S-9
50	KSYR-20	KSYR-20	OPA-50	OPA-50	AS-31	S-16
63	KSYR-20	—	OPA-63	—	AS-35	S-16
80	ORA-25	—	OPA-80	—	AS-41	d20 × w1
100	SDR-30	—	OPA-100	—	S-95	S-26

### Double acting (with magnet)

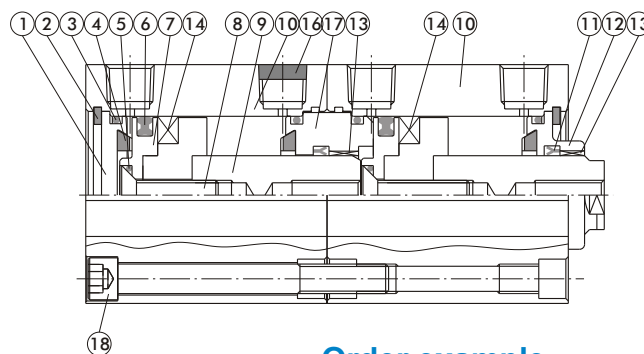

### Material

No.	Tube I.D. Part name	12	16	20	25	32	40	50	63	80	100	Q'y	Component parts (inclusion)	Repair kits (inclusion)
1	Head cover	Aluminum alloy										1	●	
2	Snap ring	Stainless steel					Spring steel					2	●	
3	Cover ring	NBR										4	●	●
4	Cushion packing	—	NBR									4	●	●
5	Piston gasket	NBR										2	●	●
6	Piston packing	NBR										2	●	●
7	Piston	Aluminum alloy										2	●	
8	Screw	SCM										2	●	
9	Piston rod	Stainless steel					Carbon steel					2		
10	Body	Aluminum alloy										2		
11	Rod packing	NBR										2	●	●
12	Rod cover	Aluminum alloy										1	●	
13	Bush	—	Bearing alloy									2	●	
14	Magnet	Plastic										2	●	
15	Spring	SWP					—					2	●	
16	Silencer	Brass					—					1	●	
17	Center cover	Aluminum alloy										1	●	
18	Screw	SCM										2	●	

### Order example Component parts

Tube I.D.	Component parts
φ 12	CP-MCJT-32-12(M)
φ 16	CP-MCJT-32-16(M)
φ 20	CP-MCJT-32-20(M)
φ 25	CP-MCJT-32-25(M)
φ 32	CP-MCJT-32-32(M)
φ 40	CP-MCJT-32-40(M)
φ 50	CP-MCJT-32-50(M)
φ 63	CP-MCJT-32-63(M)
φ 80	CP-MCJT-32-80(M)
φ 100	CP-MCJT-32-100(M)

M: With magnet

### Repair kits

Tube I.D.	Repair kits
φ 12	PS-MCJT-32-12
φ 16	PS-MCJT-32-16
φ 20	PS-MCJT-32-20
φ 25	PS-MCJT-32-25
φ 32	PS-MCJT-32-32
φ 40	PS-MCJT-32-40
φ 50	PS-MCJT-32-50
φ 63	PS-MCJT-32-63
φ 80	PS-MCJT-32-80
φ 100	PS-MCJT-32-100



Mindman

# MCJT Multiple position Double action / Female thread $\phi 12\sim\phi 100$

## COMPACT CYLINDERS



$\phi 12, \phi 16$

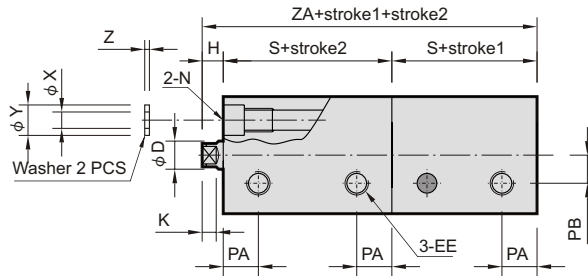
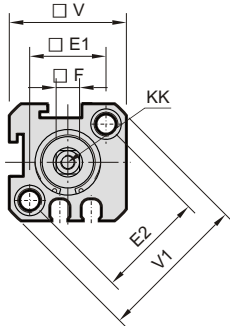

$\phi 20, \phi 25$

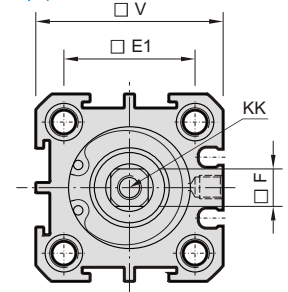

$\phi 32\sim\phi 100$

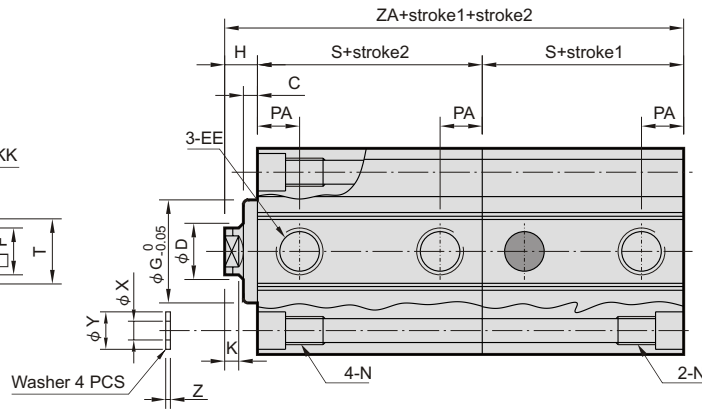
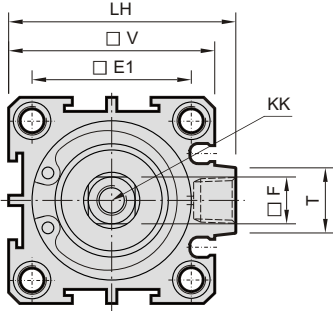

$\phi 12\sim\phi 100$  Long stroke  
(Without counter bore)

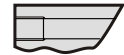

※ with magnet type: the stroke length must be over 100mm.

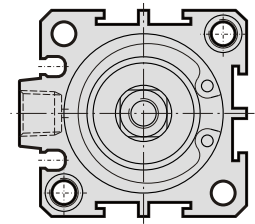

※ Stroke1: First stroke    Stroke2: Total stroke

Code Tube I.D.	C	D	E1	E2	EE	F	G	H	K	KK	LH	N	PA	PB
12	-	6	16.3	23	M5×0.8	5	-	4.5	3	M3×0.5×7depth	-	6.5×4.5depth, 4.3, M5×0.8×6depth	7.5	5.5
16	-	8	19.8	28	M5×0.8	6	-	4.5	3	M4×0.7×7depth	-	6.5×4.5depth, 4.3, M5×0.8×6depth	8	6.5
20	1.5	10	24	-	M5×0.8	8	13	5.5	3	M5×0.8×10depth	-	6.5×4.5depth, 4.3, M5×0.8×7.5depth	7.5	-
25	2	12	28	-	M5×0.8	10	17	6	3	M6×1×10depth	-	8×6depth, 5.1, M6×1×9.5depth	8	-
32	3.3	16	34	-	Rc1/8(※1)	14	22	7	3	M8×1.25×12depth	48.5	8×6depth, 5.1, M6×1×8depth	9	-
40	3.3	16	40	-	Rc1/8(※1)	14	28	7	3	M8×1.25×12depth	56.5	9.5×8depth, 6.9, M8×1.25×10depth	10	-
50	4	20	48	-	Rc1/4(※2)	17	38	9	3	M10×1.5×15depth	70	11×8.5depth, 6.9, M8×1.25×10depth	10.5	-
63	4	20	60	-	Rc1/4(※2)	17	40	9	3	M10×1.5×15depth	83	11×8.5depth, 6.9, M8×1.25×10depth	11	-
80	5	25	74	-	Rc3/8(※3)	22	45	11	4	M14×2×20depth	102	14×10.5depth, 10.5, M12×1.75×12depth	13	-
100	3	30	90	-	Rc3/8(※3)	27	45	9	4	M18×2.5×20depth	122	18.5×13depth, 12.3, M14×2×15depth	15	-

※1: without magnet with stroke=5mm, EE=M5×0.8

※3: without magnet with stroke=5mm, EE=Rc1/4

※2: without magnet with stroke=5mm, EE=Rc1/8

Code Tube I.D.	T	V	V1	X	Y	Z	without magnet		magnet	
							S	ZA	S	ZA
12	-	25	32	3.2	6.3	1	20.5	45.5	25.5	55.5
16	-	29	38	3.2	6.3	1	20.5	45.5	30.5	65.5
20	-	34	-	3.2	6.3	1	19.5	44.5	29.5	64.5
25	-	40	-	4.2	7.8	1	21	48	31	68
32	14	44	-	4.2	7.8	1	24	55	34	75
40	14	52	-	6.2	9.3	1.6	26.5	60	36.5	80
50	19	62	-	6.2	10.8	1.6	28.6	66.2	38.6	86.2
63	20	75	-	6.2	10.8	1.6	32.5	74	42.5	94
80	27	94	-	8.2	13.8	1.6	41	93	51	113
100	26	114	-	10.2	17.3	2	45	99	55	119

