

For Air

Rotary Line Cupla

Simple design air line couplings on free turn manifold

Working pressure



Valve structure



Applicable fluid



▼ RT type
(comes with dust caps)

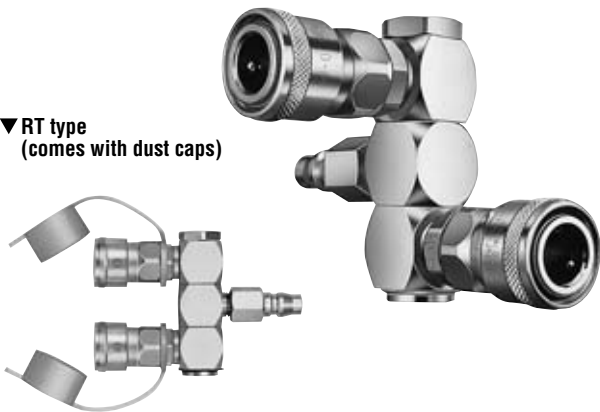

▼ RE type
(comes with dust caps)

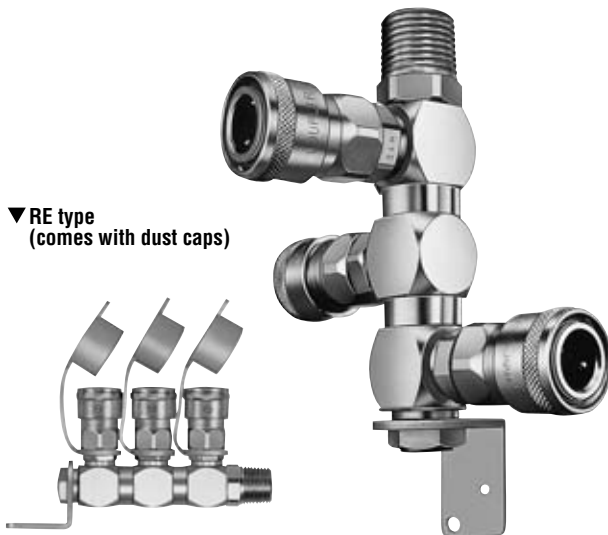

Specifications				
Body material	Body : Brass (Chrome-plated), Cupla : Steel (Chrome-plated)			
Model	RT Type (for two branch lines)		RE Type (for three branch lines)	
Size	Inlet	1/4" Hi Cupla (20PF)	Inlet	R 1/2 male thread
	Outlet	2 sockets (20 type)	Outlet	3 sockets (20 type)
Working pressure MPa (kgf/cm ²)	1.5 (15)			
Pressure resistance MPa (kgf/cm ²)	2.0 (20)			
Seal material	Nitrile rubber	Mark	NBR (SG)	Working temperature range
Working temperature range			-5°C~+60°C	Remarks
	Standard material			

Fluid Flow Direction

Fluid must run from the inlet port to the outlet ports.

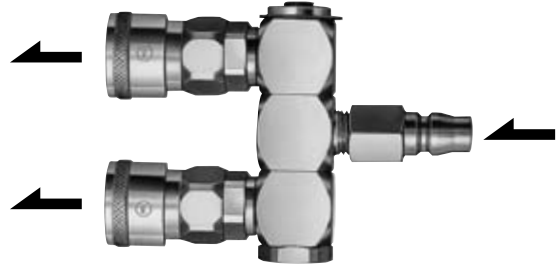

Interchangeability

Can be connected with plugs of Hi Cupla Models 20, 30 and 40. Interchangeable with each corresponding Hi Cupla Series models.

Min. Cross-Sectional Area

(mm²)

32

Suitability for Vacuum

Not suitable for vacuum application in either connected or disconnected condition.

Pressure - Flow Characteristics

[Test conditions] • Fluid : Air • Temperature : Room temperature
• Plug : 20PM (All the Socket valves are opened with 20PM)

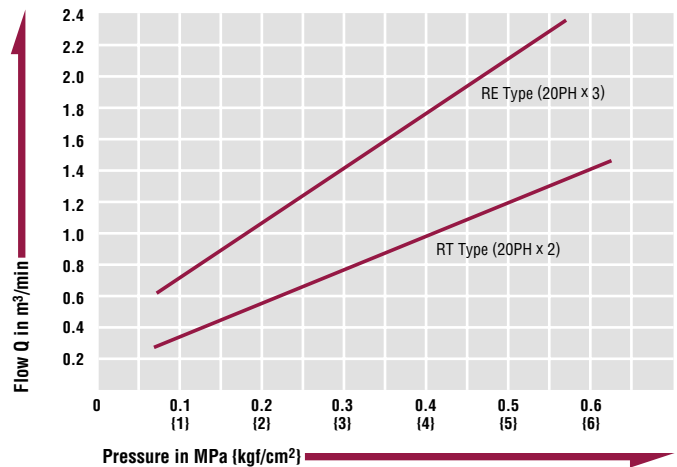

Each air outlet can be turned freely to any angle independently.

- Give you multiple outlets from single air supply source.
- Sideway air outlets are rotatable to any angle. Possible hose twists can be eliminated by the component Cuplas' swivel mechanism.
- Choose either RT type (2 outlets) or RE type (3 outlets) to suit your application.